



USER MANUAL

Studio Rail 60



Original Instructions

Studio Rail 60 Range:

T84000 - T84516

Studio Rail 60 is an extruded aluminium rail system available with all the components necessary for a comprehensive overhead Studio Rail system. Available in a choice of natural aluminium or black powder coated finish, Studio Rail features a unique joint pin system which aids rail alignment and installation. There is a range of brackets designed to suspend the rail in most situations.

Studio Rail 60 is available in straight lengths from two to six metres and six radius curves. Non-standard radius curves can be made to special order.

Main features:

- Extruded aluminium section.
- Can be cut to length on site.
- Single swipe or overlap curtains.
- Walkalong systems only.

Studio Rail 60 is strictly for professional use. Only competent persons are permitted to install and use Studio Rail 60. A competent person in this respect is an individual with relevant technical education, training and/or experience enabling him or her to perceive risks and to avoid hazards occurring during use of a product.

Doughty has endeavoured to deliver the highest degree of accuracy possible. However, continuous improvement of our products is a Doughty Policy. Therefore, product specifications are subject to change without notice. Readers and users are encouraged to notify Doughty of errors and send in suggestions for improvement. All communications will be carefully considered for future printings of this manual and changes to our products.

Studio Rail 60 Range - Straight Rails

- T84000** - Studio Rail 60 - Straight 2.0m - Silver
- T84035** - Studio Rail 60 - Straight 2.0m - Black
- T84005** - Studio Rail 60 - Straight 3.0m - Silver
- T84040** - Studio Rail 60 - Straight 3.0m - Black
- T84010** - Studio Rail 60 - Straight 4.0m - Silver
- T84045** - Studio Rail 60 - Straight 4.0m - Black
- T84015** - Studio Rail 60 - Straight 6.0m - Silver
- T84050** - Studio Rail 60 - Straight 6.0m - Black

Dimensions in mm

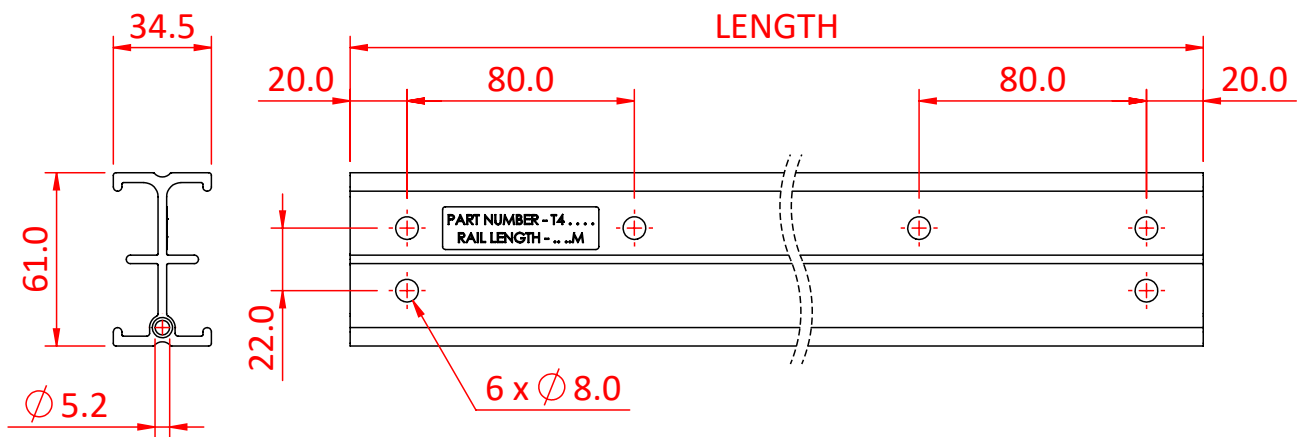

Studio Rail 60 Range - Curved Rails

- T84017 - Studio Rail 60 - Curve R75cm - Silver
- T84052 - Studio Rail 60 - Curve R75cm - Black
- T84018 - Studio Rail 60 - Curve R90cm - Silver
- T84053 - Studio Rail 60 - Curve R90cm - Black
- T84019 - Studio Rail 60 - Curve R105cm - Silver
- T84054 - Studio Rail 60 - Curve R105cm - Black
- T84020 - Studio Rail 60 - Curve R120cm - Silver
- T84055 - Studio Rail 60 - Curve R120cm - Black
- T84025 - Studio Rail 60 - Curve R135cm - Silver
- T84060 - Studio Rail 60 - Curve R135cm - Black
- T84030 - Studio Rail 60 - Curve R150cm - Silver
- T84065 - Studio Rail 60 - Curve R150cm - Black

Dimensions in mm

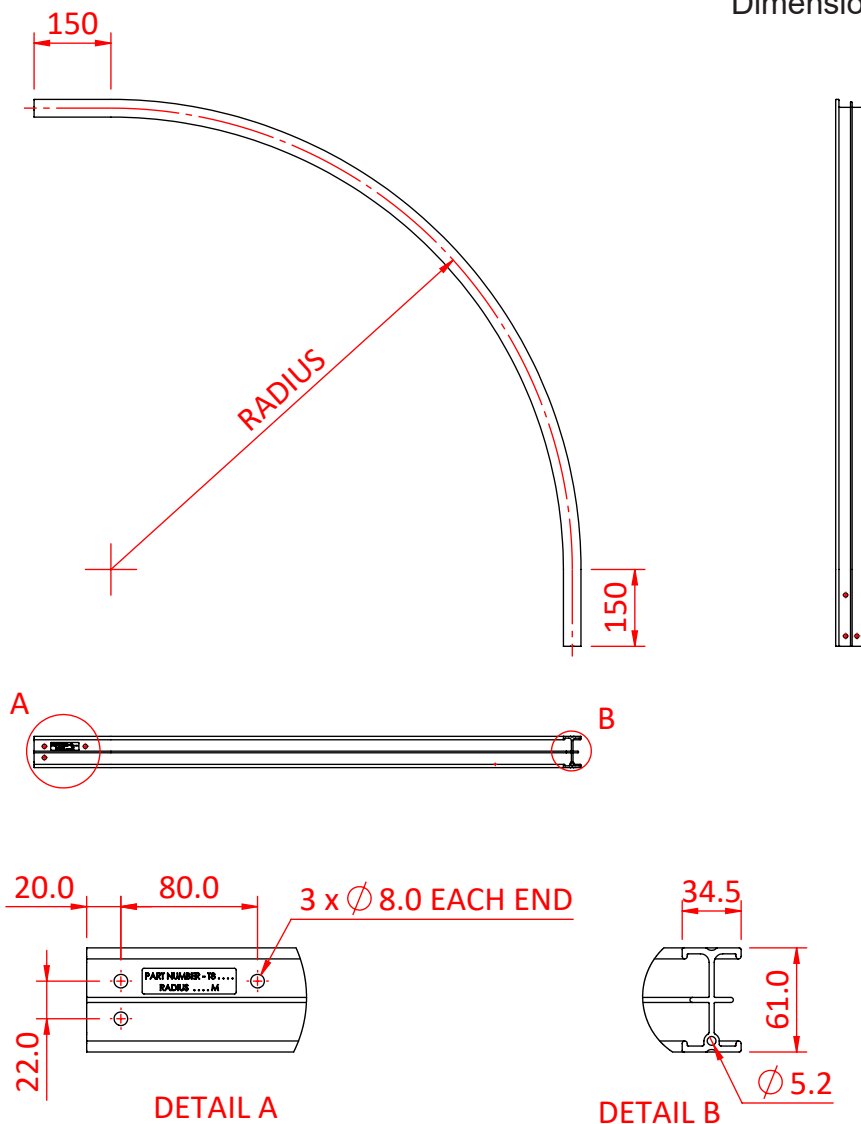

Studio Rail 60 Range - Accessories

- T84070** - Studio Rail 60 - Joint Kit (includes Joint Pin) - Silver
- T84071** - Studio Rail 60 - Joint Kit (includes Joint Pin) - Black
- T84075** - Studio Rail 60 - Joint Pin X 5
- T84080** - Studio Rail 60 - End Stops X 4
- T84085** - Studio Rail Clamps X 2
- T84086** - Studio Rail 40mm Clamps X 2
- T84105** - Studio Rail 60 - Slotted Wall Bracket 200mm (Single Rail)
- T84106** - Studio Rail 60 - Slotted Wall Bracket 350mm (Double Rail)
- T84107** - Studio Rail 60 - Slotted Wall Bracket 500mm (Triple Rail)
- T84110** - Studio Rail 60 - Double Rail Spacer Plate
- T84115** - Studio Rail 60 - Triple Rail Spacer Plate
- T84116** - Studio Rail 60 - Single Ceiling Bracket with Wall Tie Option
- T84117** - Studio Rail 60 - Double Ceiling Bracket with Wall Tie Option
- T84118** - Studio Rail 60 - Triple Ceiling Bracket with Wall Tie Option
- T84120** - Studio Rail 60 - Ceiling Bracket - 25mm
- T84121** - Studio Rail 60 - Ceiling Bracket - 50mm
- T84125** - Studio Rail 60 - Flat Ceiling Bracket -100mm
- T84130** - Studio Rail 60 - 90° Crossover Bracket
- T84145** - Studio Rail 60 - Extension Bracket - 350mm
- T84150** - Studio Rail 60 - Extension Bracket - 650mm
- T84160** - Studio Rail 60 - Extension Bracket - Adjustable
- T84165** - Studio Rail 60 - Adjustable Angle Bracket
- T84170** - Studio Rail 60 - Adjustable Stud Hanger - M10
- T84175** - Studio Rail 60 - Adjustable Stud Hanger - M12
- T84180** - Studio Rail 60 to Tube Bracket
- T84185** - Studio Rail 60 - 4 Wheel Car with 5/8" Spigot & Brake
- T84186** - Studio Rail 60 - 4 Wheel Car with 5/8" Mini Spigot & Brake
- T84205** - Studio Rail 60 - 6 Wheel Car with 28mm Receiver Carriage & Brake
- T84215** - Studio Rail 60 - 4 Wheel Double Swivel Car & Brake
- T84217** - Studio Rail 60 - Articulated Carriage
- T84220** - Studio Rail 60 - Cable Car X 5
- T84225** - Studio Rail 60 - Curtain Car X 5
- T84230** - Studio Rail 60 - Cupped Curtain Brake
- T84260** - Studio Rail 60 - Drilling Jig
- T84249** - Operating Poles 1600mm to 2800mm
- T84250** - Operating Poles 2000mm to 3700mm
- T84251** - Operating Poles 2100mm to 4600mm
- T84252** - Operating Poles 2100mm to 5500mm
- T84253** - Operating Poles 2750mm to 7400mm
- T84515** - Studio Rail 60 - Swivel Arm fitted on a 6 Wheel Braked Carriage
- T84516** - As T84515 with Ø25mm x 2m black tube.
- T63796** - Nylon Twin Hook

LIMITATIONS OF USE

- Studio Rail 60 can be operated in -20° Celsius up to +60° Celsius.
- Studio Rail 60 is for indoor use only.
- The use of Studio Rail 60 is the sole responsibility of the user.
- To use Studio Rail 60 the user must observe the instructions to be found in this manual.
- All persons who use Studio Rail 60 must be acquainted with this manual and must be informed about its potential hazards.
- It is also imperative to observe the local accident prevention regulations and/or occupational health and safety regulations.
- Using this product for any other purpose than that described in this manual is considered contrary to its designated use and the manufacturer cannot be held liable for any damage resulting from such use.
- The manufacturer is not liable for indirect consequential damage and financial loss. The manufacturer shall not be liable for any changes made to product components nor for any damage resulting from such changes.

MODIFICATION

Studio Rail 60 components should not be modified in any way. If there is a requirement for non-standard Studio Rail 60 parts for a special purpose please contact your Doughty agent.

Only use Doughty approved spares.



Warning

- Do not exceed any working load limit (WLL) indicated.
- When installing or using Studio Rail 60 appropriate personal protective equipment (PPE) must be used suitable for the environment being worked in.
- Ensure the installation is suitable for the application.
- Studio Rail 60 shall be inspected by a competent person as often as required but with a minimum of once a year and maintain written records.
- Studio Rail 60 must be taken out of service immediately if, during use, repair or maintenance any serious damage is discovered.
- Repairs can be undertaken only by authorised (Doughty trained) personnel. If in any doubt contact the manufacturer.

TRANSPORT AND STORAGE

Before Studio Rail 60 systems are put into storage they must be checked for defects. Defective Studio Rail 60 components must be clearly marked and put aside so they cannot be re-used.

Ensure the product is stored and kept in a dry, ventilated place to avoid corrosion.

Installation and Operation

- Installation should only be carried out by a competent person familiar with this type of equipment.
- All suspension points must be assessed to ensure they are adequate to suspend the load.
- A typical Studio Rail System will be installed at a height such that any failure could be hazardous.
- Before starting the installation, the load for each support should be calculated allowing for the weight of all the track and accessories as well as the curtain whether open or bunched or part bunched as during opening if using curtain runners.
- The maximum load per curtain runner is 10kg and has a recommended spacing of 300mm when the cloth is open. Swivel hooks are best used on the curtains instead of eyelets or ties.
- Suspension points must be fitted within 250mm of the end of the rail irrespective of the size of the installation.
- When joining rails, a support must be used within 50mm of the joint.
- Studio Rail can be cut to size but care must be taken to remove all sharp edges.

Safety Instructions and Loading Information

Studio Rail has a working load limit (WLL) of 100Kg per 1500mm suspension points unless arranged otherwise by a qualified person in liaison with Doughty Engineering Ltd.

When using Studio Rail accessories, care must be taken not to exceed the WLL of the component or the WLL of the complete Studio Rail structure.

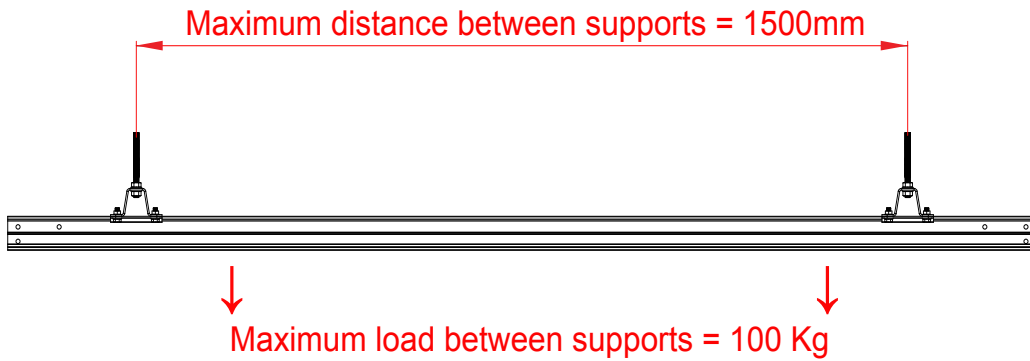

Studio Rail joints should be supported as illustrated. Unsupported joints must be treated as a pair of cantilevers.

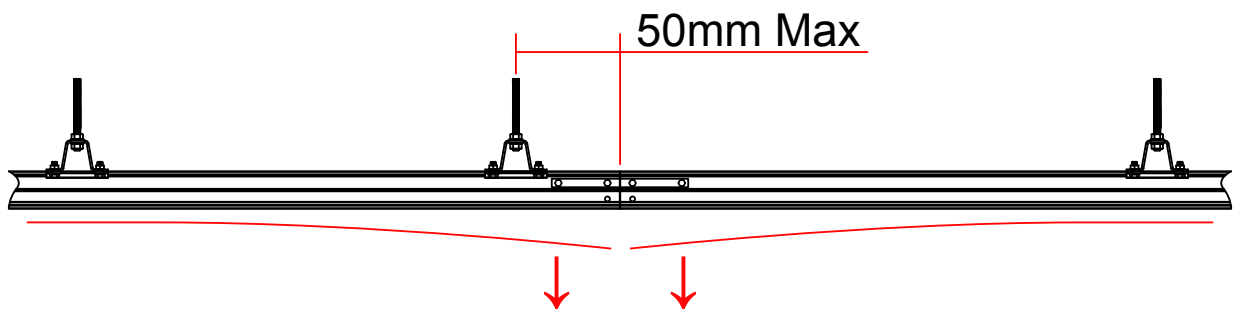

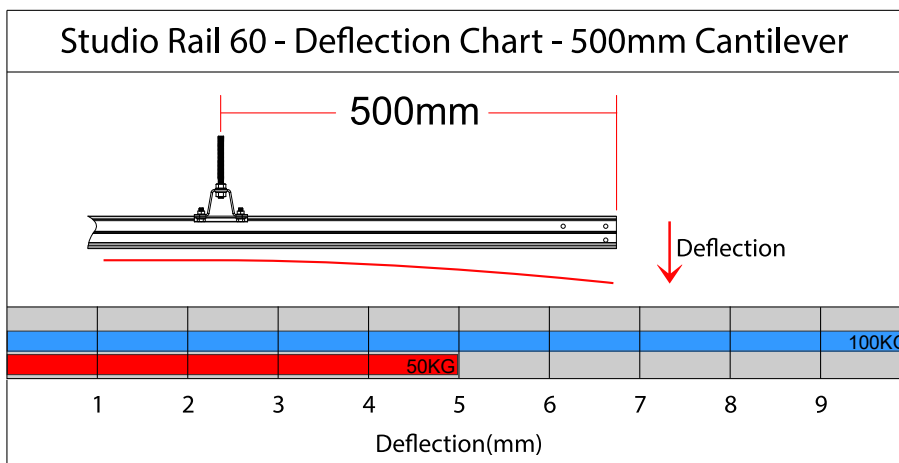
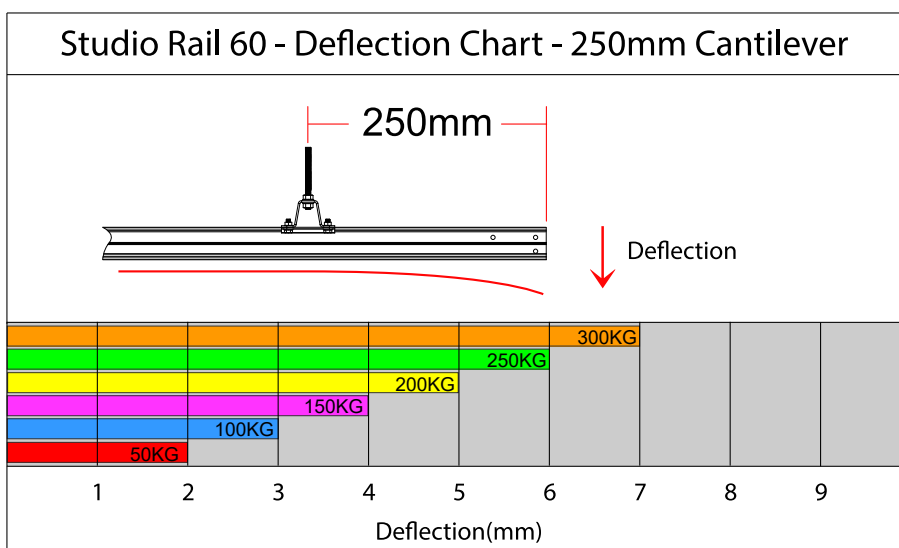
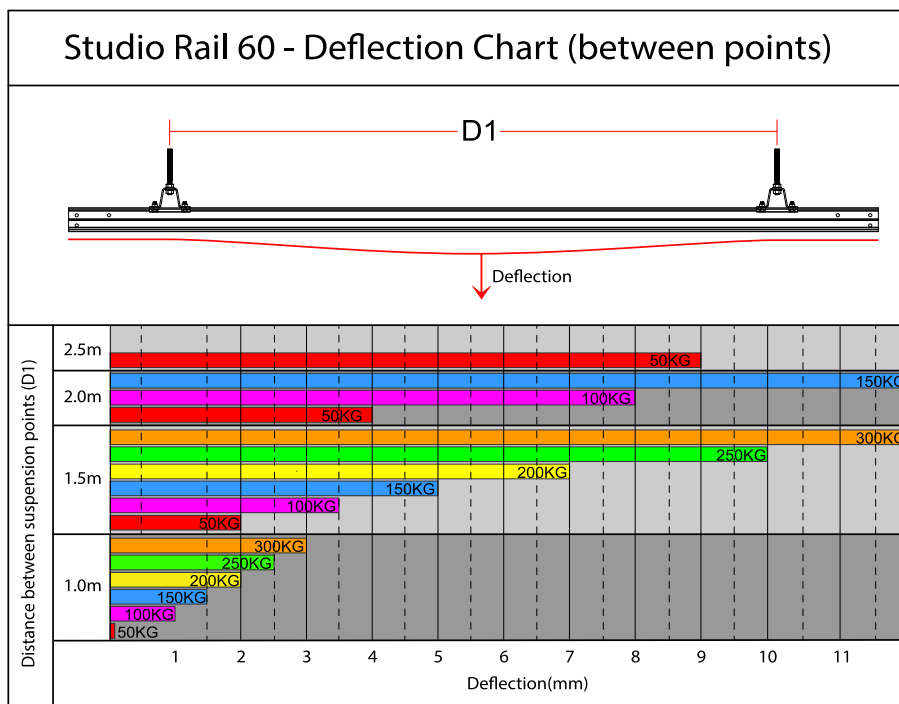

Moving Rail Loading

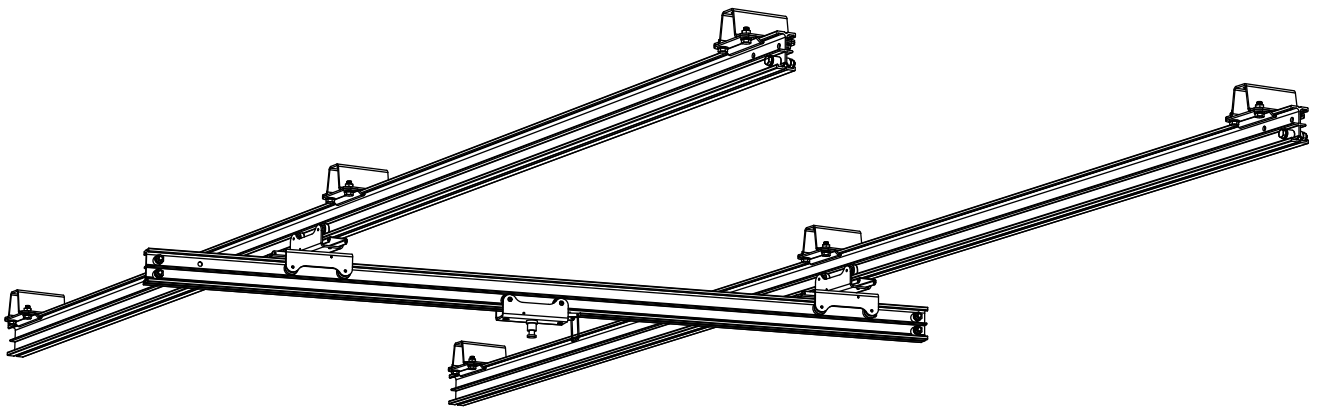
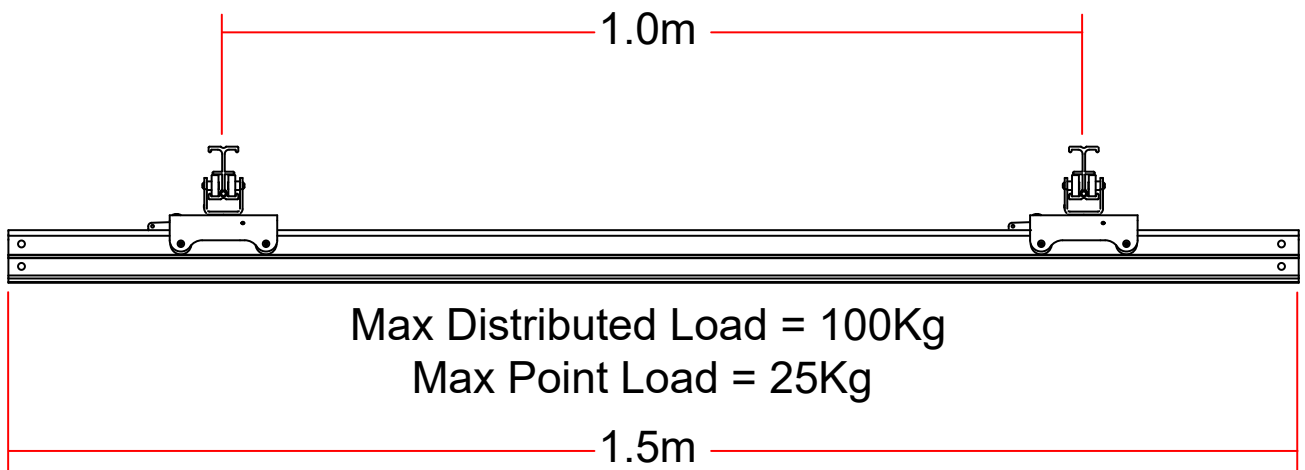

T84110 - Double Spacer Plate - Not Suitable for Suspension

The Double Spacer Plate is used to space two rails at 150mm between rail centres. The 150mm matches the distance between two curved rails if used. The double spacer plate is not to be used for suspension.

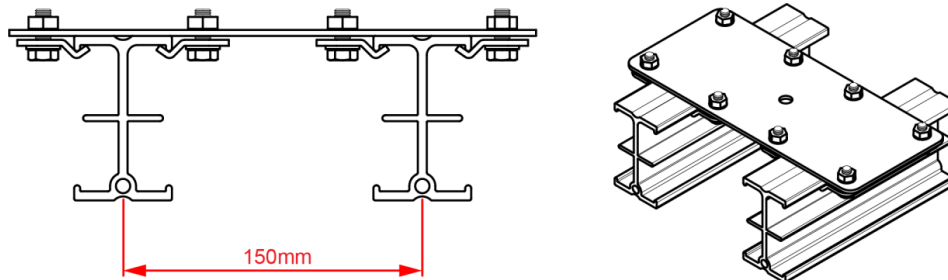

T84115 - Triple Spacer Plate - Not Suitable for Suspension

The Triple Spacer Plate is used to space three rails at 150mm centres. The 150mm matches the distance between two curved rails if used. This plate should not be used for suspension.

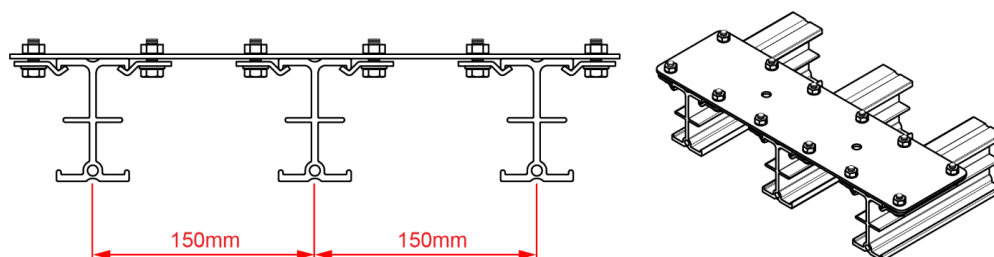

T84117 - Double Ceiling Bracket - WLL 100Kg

A Double Ceiling Bracket designed to suspend two rails. Rails are spaced at 150mm centres to match multiple curved rails. The bracket also features a hole in the end plate for a wall tie.

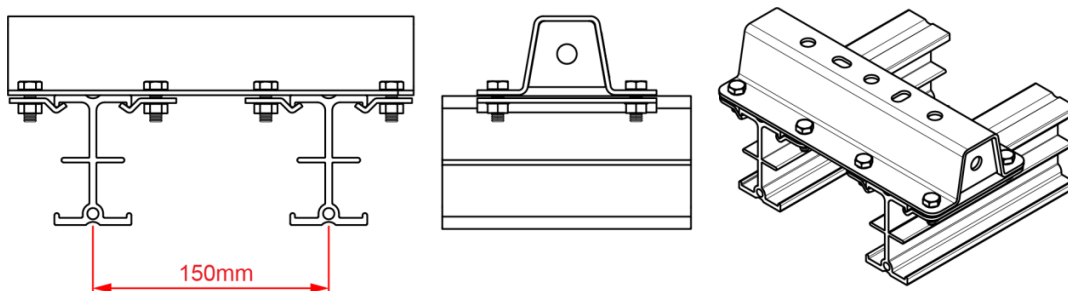

Suspension Brackets

T84118 - Triple Ceiling Bracket - WLL 100Kg

A Triple Ceiling Bracket designed to suspend three rails. Rails are spaced at 150mm centres to match multiple curved rails. The bracket also features a hole in the end plate for a wall tie.

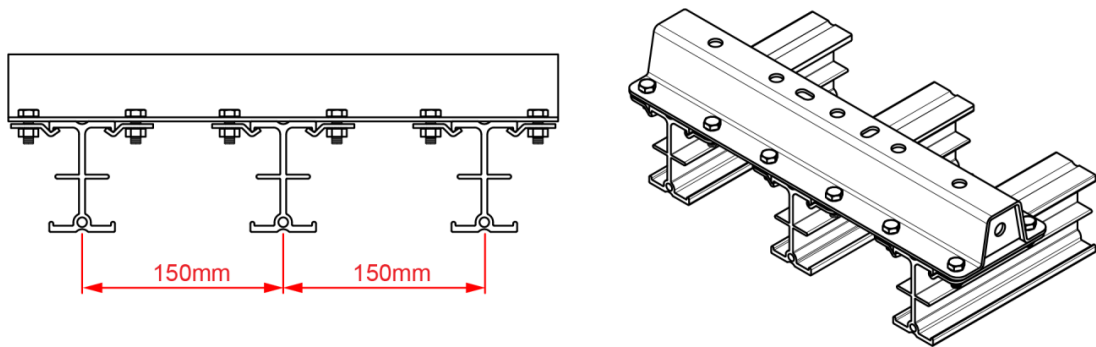

T84120 - Ceiling Bracket 25mm - WLL 100Kg

Designed to enable Studio Rail to be suspended from M10 or M12 studding with a small amount of adjustment for uneven fixings.

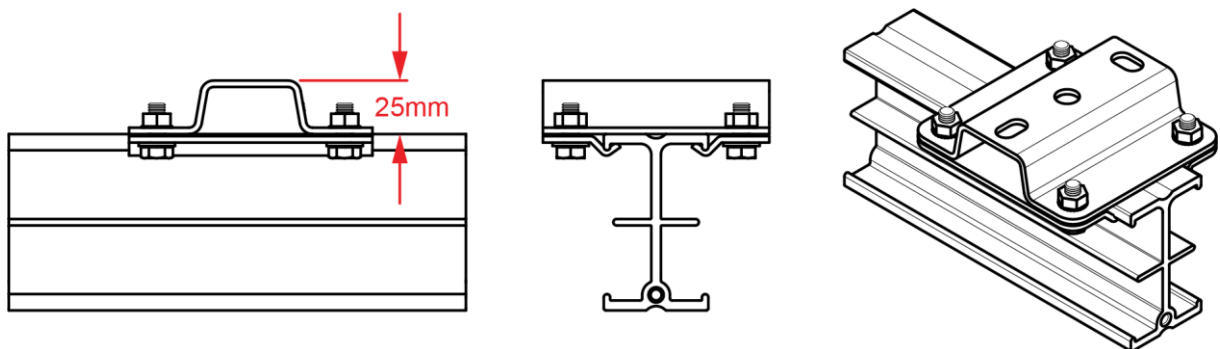

Suspension Brackets

T84121 - Ceiling Bracket 50mm - WLL 100Kg

Designed to enable Studio Rail to be suspended from M10 or M12 studding with 50mm of adjustment for uneven fixings.

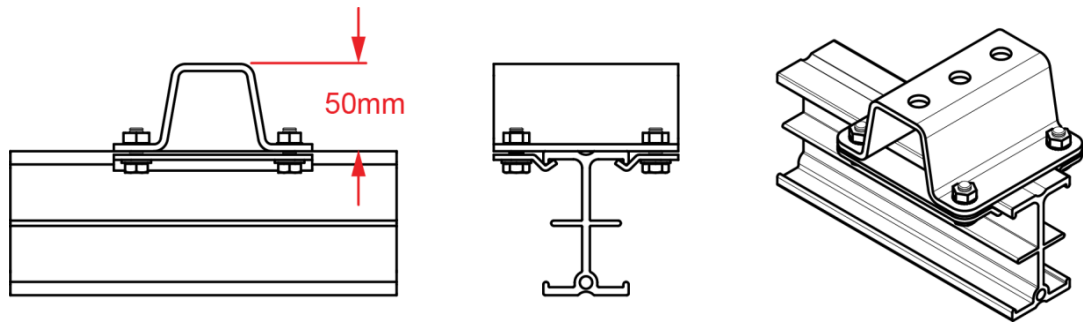

T84125 - Flat Ceiling Bracket 100mm - WLL 100Kg

A flat ceiling bracket supplied with 10mm countersink hole to enable Studio Rail to be fixed directly to a ceiling/slab with very little loss in height.

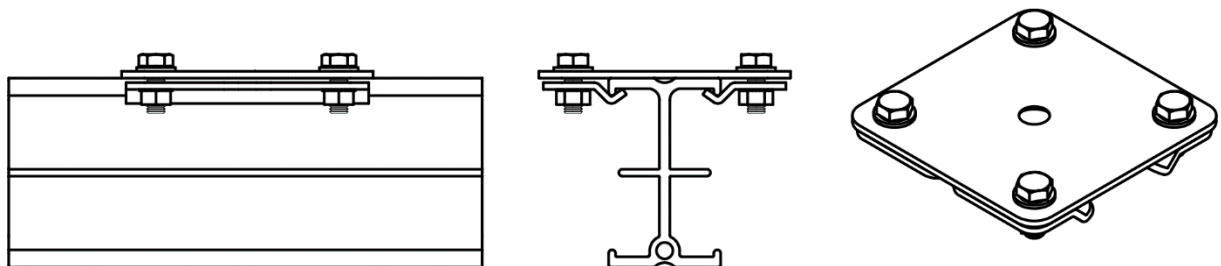

T84130 - 90° Cross Over Bracket - WLL 100Kg

The Cross Over Bracket fixes two Studio Rails perpendicular to each other.

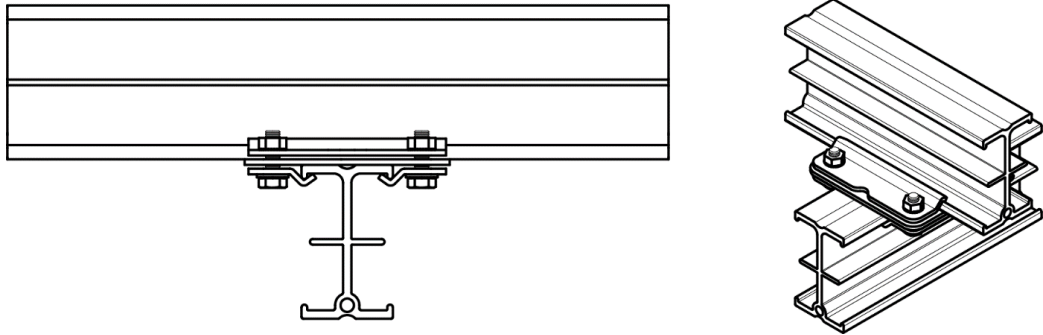

T84145 - Extension Bracket - WLL 100Kg - 350mm Drop

T84150 - Extension Bracket - WLL 100Kg - 650mm Drop

Fixed Extension Brackets are used to suspend Studio Rail from a ceiling/slab at a height. The brackets have either a 350mm or 650mm drop.

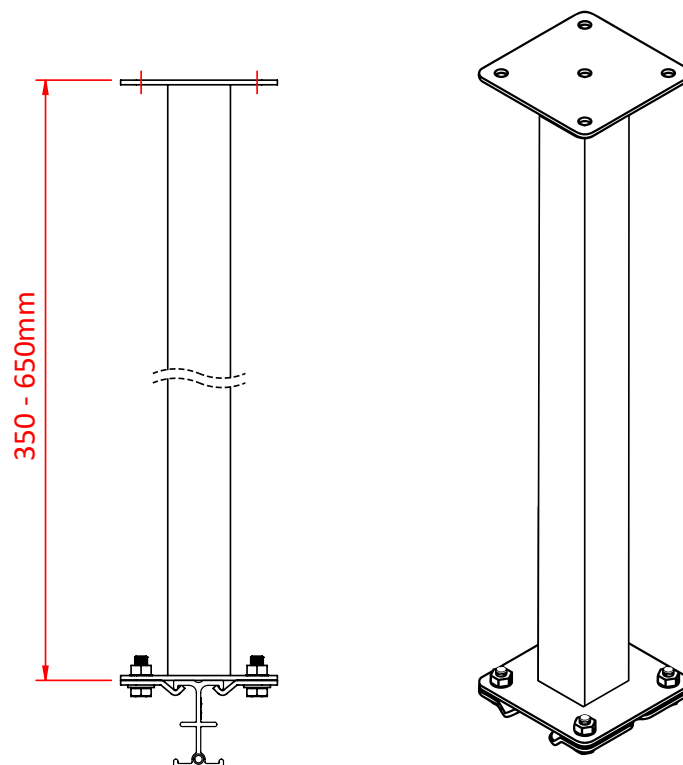

Suspension Brackets

T84160 - Extension Bracket - WLL 100Kg

Extension brackets are used to suspend Studio Rail from a ceiling/slab at a height which is adjustable between 300 & 400mm at 25mm increments.

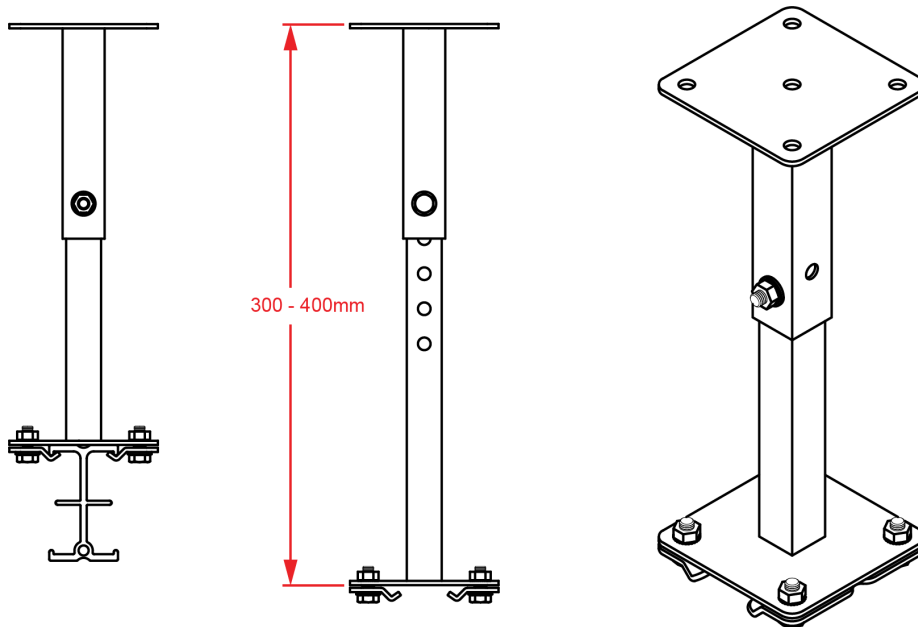

T84165 - Adjustable Angle Bracket - WLL 100Kg

A bracket designed to suspend Studio Rail from an angled surface. The surface angle can be from 0 - 45°.

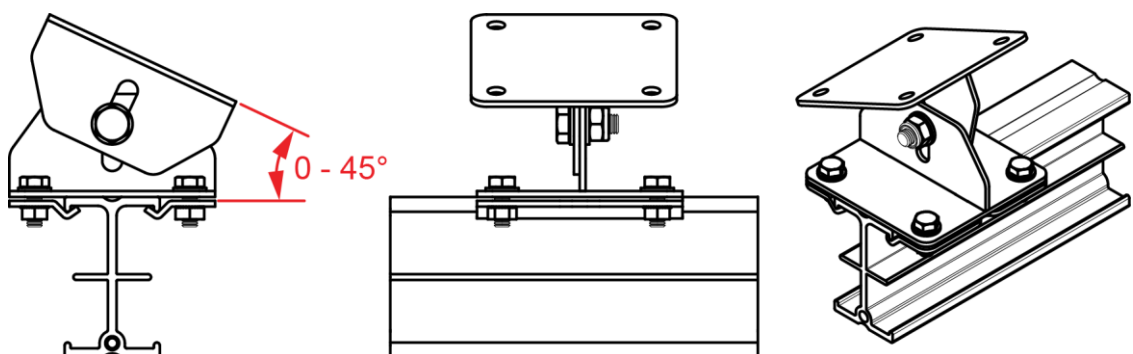

Suspension Brackets

T84170 - Adjustable Stud Hanger - WLL 50Kg - M10 Studding

T84175 - Adjustable Stud Hanger - WLL 50Kg - M12 Studding

Supplied with rail clamps, these brackets are used to suspend Studio Rail from either an M10 or an M12 studding.

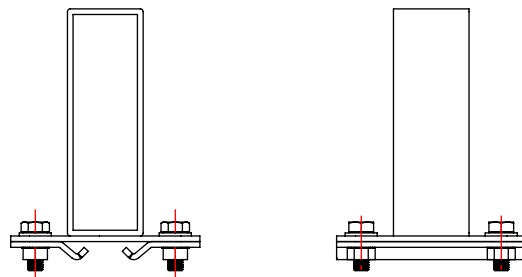
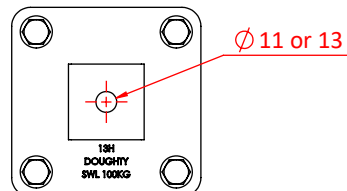

T84180 - 90° Rail to Tube Bracket - WLL 100Kg

A bracket designed to suspend Studio Rail from a 48 to 51mm diameter barrel. Studio Rail can be suspended either parallel or perpendicular to the barrel.

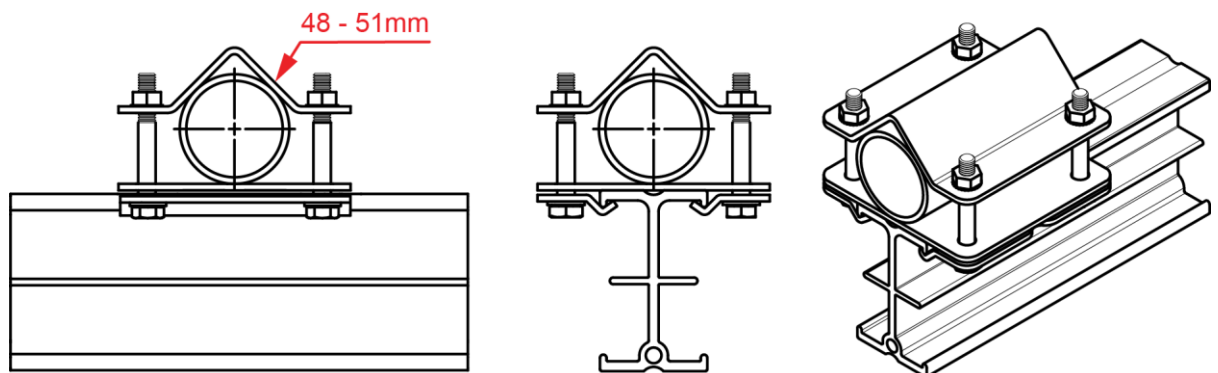

T84220 - Cable Carriage - WLL 6Kg

The cable carriage is designed to support cables used with luminaires etc on the Studio Rails. The cable carriage is supplied with a cable tie saddle.

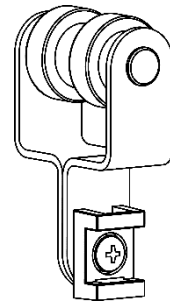

T84225 - Curtain Carriage - WLL 10Kg

Curtain Carriages are used to suspend curtains/drapes. This carriage has a WLL of 10kg and is recommended to be used at 300mm intervals.

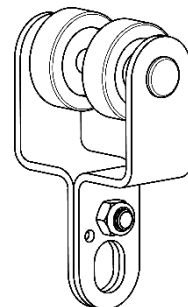

T84230 - Cupped Curtain Brake

The Cupped Curtain Brake is typically used to hold or tension one or both ends of a curtain/drape. This brake is fitted with a pole operated cup.

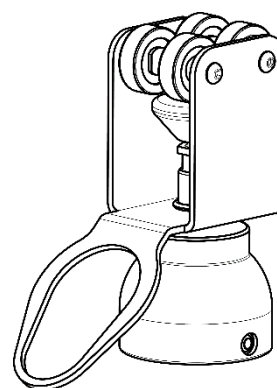

T63796 Nylon Twin Hook - WLL 6Kg

Hooks to be used with curtain carriages to hang curtains/drapes.

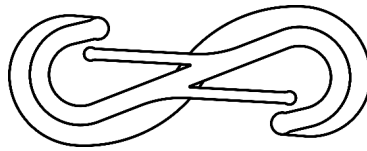

T84185 - 4 Wheel Carriage - 16mm Spigot - WLL 50Kg

This carriage is typically used to suspend luminaires etc fitted with a 16mm receiver and is fitted with a friction brake as standard.

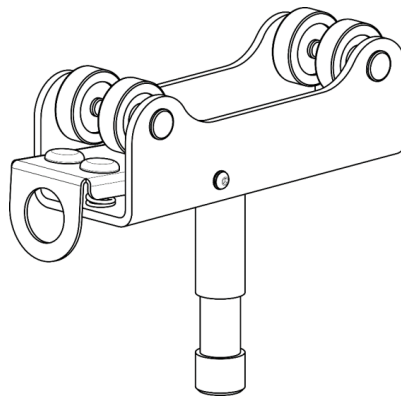

T84186 - 4 Wheel Carriage - 16mm Mini Spigot - WLL 50Kg

This carriage is typically used to suspend luminaires etc fitted with a 16mm receiver and is fitted with a friction brake as standard.

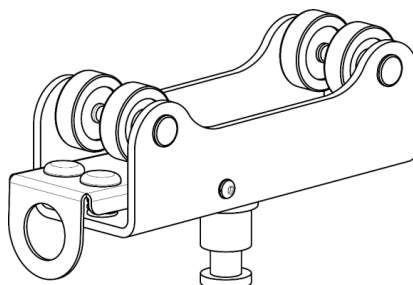

T84205 - 6 Wheel Carriage - 28mm Receiver - WLL 100Kg

This carriage is used to suspend luminaires etc with a 28mm spigot and is fitted with a friction brake as standard.

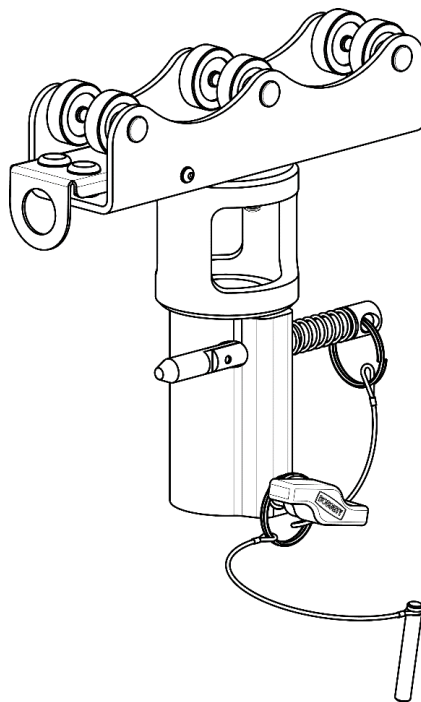

T84215 - 4 Wheel Double Swivel Carriage - WLL 75Kg

The Double Swivel Carriage enables two rails to be mounted on top of one another and is ideal for use where two parallel rails are installed with moving rails to suspend luminaires. Both top and bottom carriages have brakes with the top carriage having a loop for pole operation.

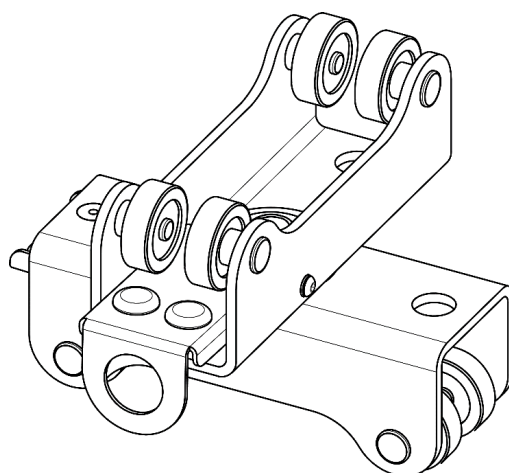

T84217 - 4 Wheel Articulated Carriage - WLL 200g

The Studio Rail Articulated Carriage can be used with any size radius curves.

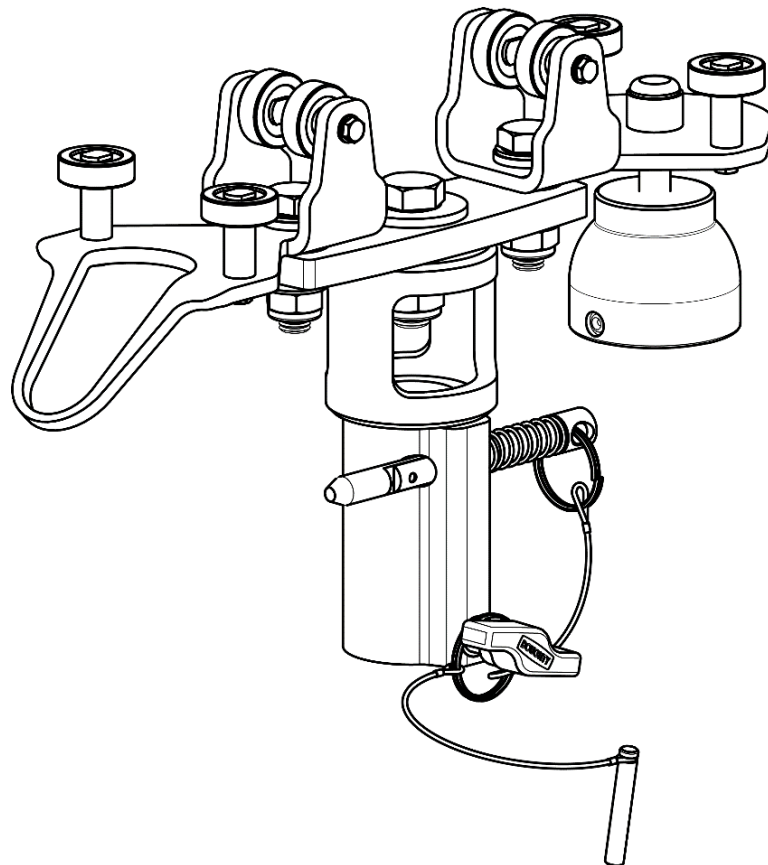

T84070 - Joint Kit - Silver

T84071 - Joint Kit - Black

The joint kit is used to join two rail lengths. This joint must be supported as shown on page 8.

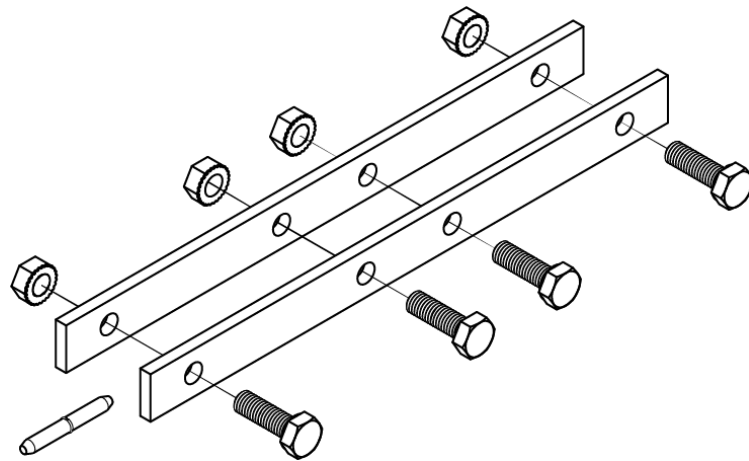

T84080 - End Stops x 4

End stops are supplied in packs of 4 and are used to stop carriages leaving rail ends.

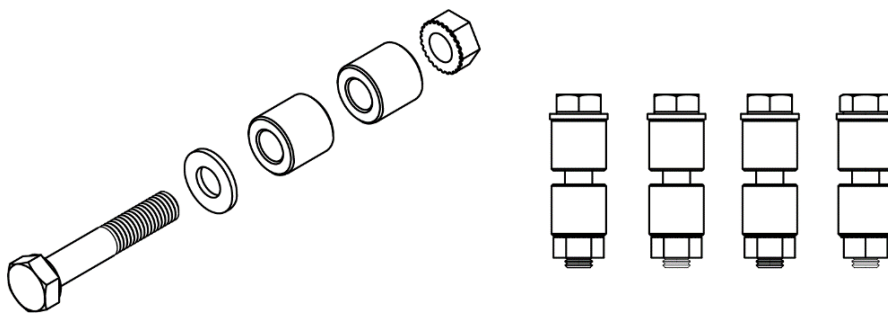

T84260 - Drilling Jig

A drilling jig to enable cut rails to be drilled accurately for a joint kit.

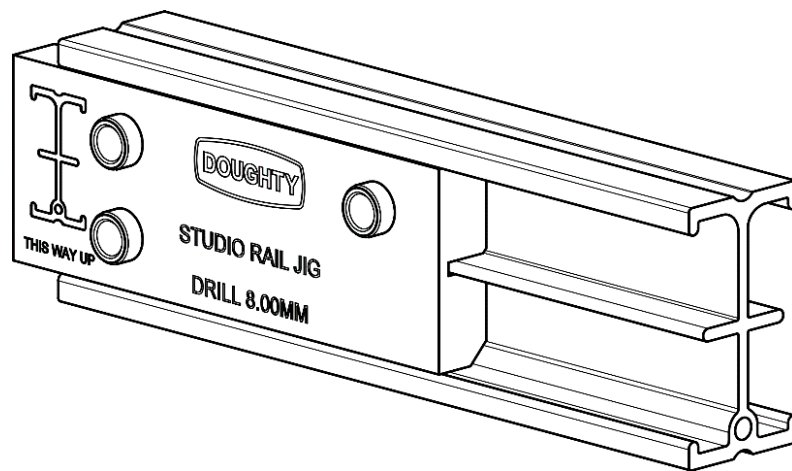

Joining Studio Rail

Studio Rails are joined with a joint kit. Rail can be cut on site and a drilling jig is available to drill the rail end accurately to suit the joint kit. The joint used M8 fixings requiring 13mm socket/spanners.

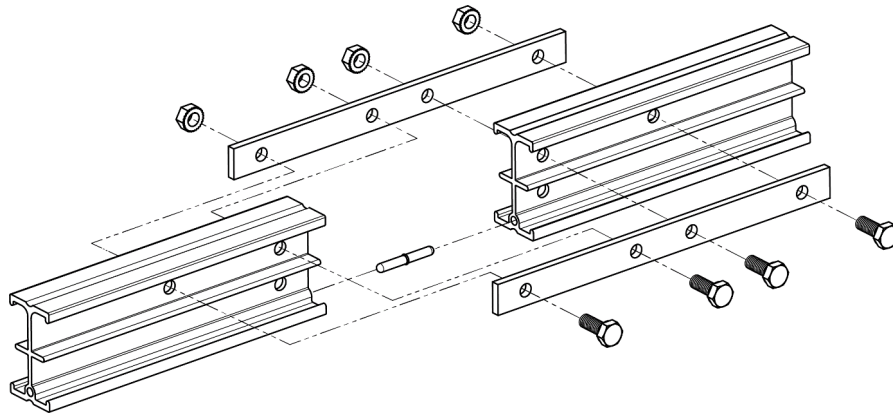

Mounting Carriages on Studio Rail

Carriages are mounted on Studio Rail by sliding the wheels into the lower section of the rail. Please note, prior to fitting the carriages, consideration must be given to fitting the end stops such that the front and rear carriages are prevented from traversing off the end of the rail.

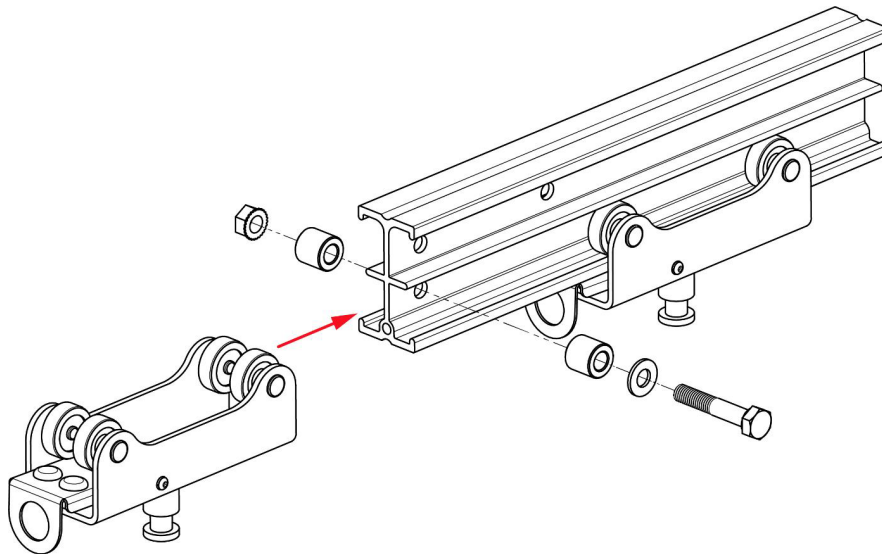

Moving Carriages with a friction brake.

Carriages with a friction brake can be traversed using an operating pole. Carriages can be positioned using the pole to release the brake by pulling down the brake loop and then moving the carriage into the desired position. Releasing the friction brake prevents the carriage running freely.

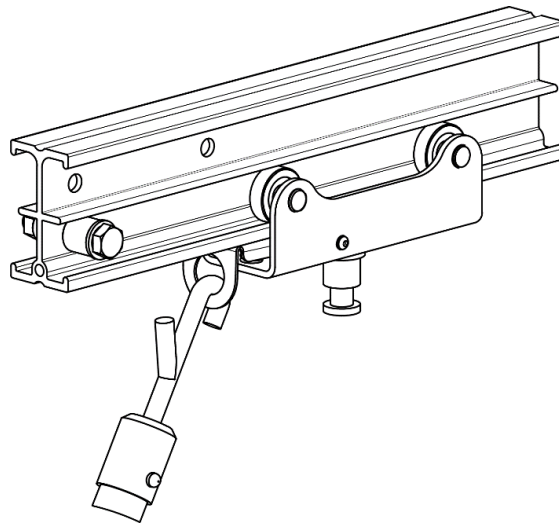

Moving Carriages with Pole Operated Cup Brake

Carriages with a pole operated cup brake can be moved by turning the pole cup to release the brake using an operators pole. The carriages can then be moved into position and the brake reapplied using the operator pole.

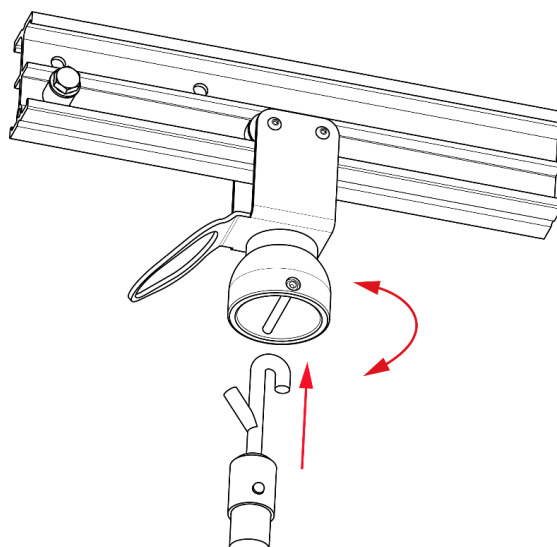

Fitting Equipment to Carriages

Carriages fitted with a 16mm spigot are designed to accept equipment with a 16mm receiver. The spigot has a machined groove to accommodate the locking screw in the receiver.

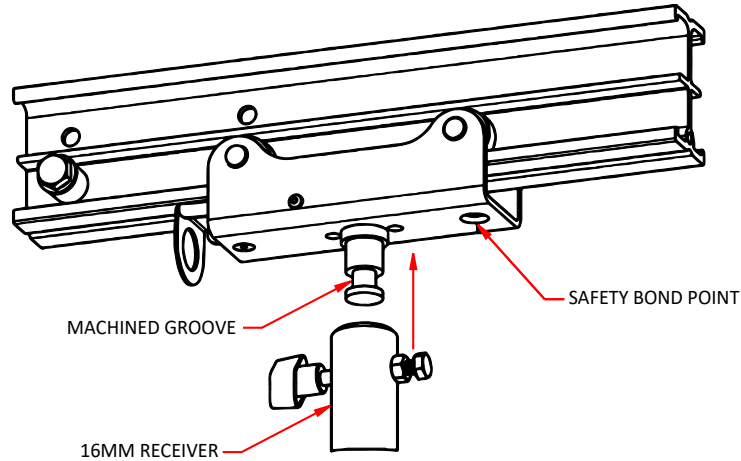

Carriages fitted with a 28mm spigot are designed to accept equipment fitted with a 28mm spigot. The receiver has three safety points incorporated into its design. The first point is a safety pin. This pin takes the initial weight of the equipment being suspended. The second point is the sword pin which secures the spigot in the receiver and still allows the spigot to rotate. The third point is the Doughty knob which stops the spigot rotating in the receiver.

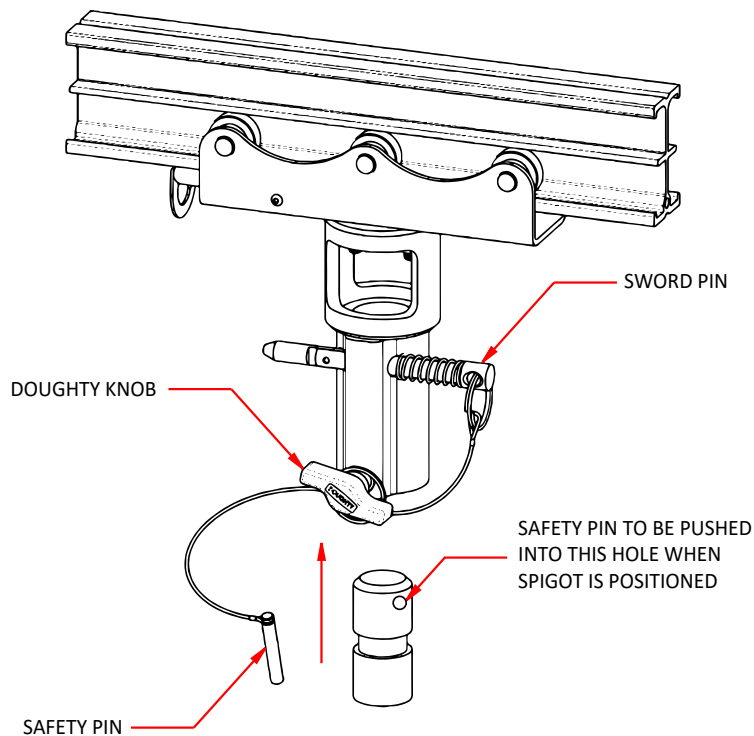

Using Double Swivel Carriages

Double swivel carriages are designed to be used in pairs to mount a moving rail to a pair of parallel rails. The moving rail can be positioned using the operator pole hook to release the friction brake on the double swivel carriages. Final adjustment can be achieved by pushing/pulling the carriages. End stops must be fitted to the upper section of the moving rail to stop the rail sliding through the carriages and becoming dismounted. End stops are also fitted to the lower section of the moving rail to stop equipment from traversing off the ends of the rails. The friction brakes serve to prevent carriages running freely.

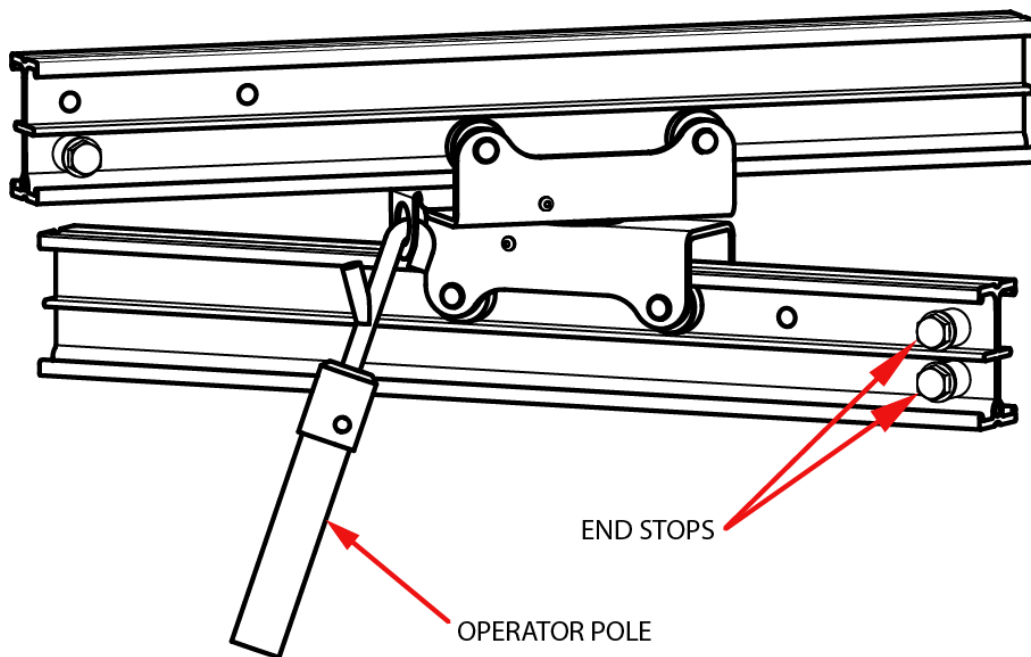
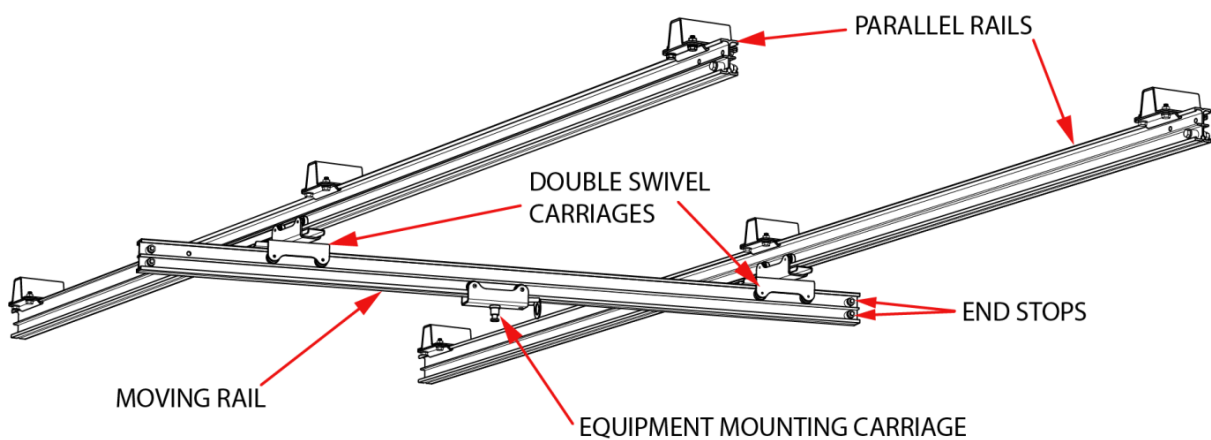

Upon installation record the following:

- Type of Studio Rail 60.
- Place and date installed.
- Name and title of installer and organisation.

MAINTENANCE AND INSPECTION

Maintenance must only be carried out by approved personnel. Approved personnel must make regular checks of the product. If any damage is seen, including cracks, deformation or missing parts, the product must be removed from service and returned to an Approved Service Agent for evaluation/repair. A full list of approved service agents can be found at www.doughty-engineering.co.uk. Approved personnel must carry out a visual inspection and a functional test before every use.

Approved personnel must carry out more detailed inspection and testing of the product on a regular basis depending on the usage of the product. Written records should be kept from the date the product is put into operation.

RECORDS

An inspection table can be found at the back of this manual where the maintenance and inspection history of the Studio Rail 60 can be recorded.



Warning

The installer/operator must read and understand the instruction manual before using the equipment. Operators should be adequately instructed and fully understand the safe use of the equipment before use.

Failure to carry out maintenance as necessary, including the replacement of parts to the correct standard could render the equipment unsafe and the manufacturer cannot accept any responsibility in this respect.

Only use approved spare parts. Do not use this equipment for a purpose that it is not intended. Do not modify the equipment as this could lead to a critical failure. Retain this manual for future reference.

DISPOSAL

Products that are no longer needed can be scrapped. Preferably remove all and aluminium steel parts, store part separately before offering them to a scrapping company. The following alloys are used:

- Mild Steel
- Steel 8.8
- Aluminium alloy 6082 T6

WARRANTY

- For a period of 12 months we undertake to repair, free of charge any damage attributable to faulty materials or workmanship, provided that the appliance is forwarded, freight paid, to our works or one of the Doughty appointed service agents.
- The guarantee-period begins on the day of the delivery, proven by a purchase receipt like an invoice or delivery note or their copies.
- The guarantee only is applicable for new equipment.
- The guarantee does not cover damage due to transport damage, negligent handling, overload or parts subject to normal wear and tear. Nor damages that originate from a case of misuse because of non-observance the instructions in this manual.
- The fitting of non-original replacement parts or modifications of design by third parties invalidates the guarantee.
- Guarantee repairs do not renew nor extend the guarantee-period.
- In case of a claim under the guarantee or spare part requirements please contact your Doughty service agent.
- The manufacturer is not liable for indirect consequential damage or financial loss.
- The manufacturer is not liable for any changes made to the Studio Rail 60 or for any damage resulting from such changes.

Installation & Inspection Report

INSTALLATION

Part No.....	Serial No.....
Customer.....	Location.....
Installation Company.....	
Installed By.....	

INSPECTED BY	DATE	ESTIMATED OPERATIONS	NOTES	SIGNATURE



Engineering Ltd

EC-DECLARATION OF CONFORMITY

According to the Machinery Directive 2006/42/EEC Annex II

Doughty Engineering Ltd

Crow Arch Lane
Ringwood
Hampshire
BH24 1NZ

Herewith declares that:

**T84000, T84005, T84010, T84015, T84035, T84040, T84045, T84050, T84017,
T84018, T84019, T84020, T84025, T84030, T84052, T84053, T84054, T84055,
T84060, T84065**

Studio Rail 60

Is in compliance with the following harmonized standards/standards/regulations.

Machinery Directive 2006/42/EEC annex II

- BS 7906-1:2005 - Lifting Equipment for Performance, Broadcast and Similar Applications;
- DGUV 17 – Regulations for Stages and Studios

Signed for and behalf of **Doughty Engineering Ltd**

Name **Dan Phillips**

A handwritten signature in black ink, appearing to be "D.P.", written over a small circular mark.

Position **Company Director** being the person responsible appointed by the manufacturer.

Company Registration No. London 972614
Registered Office: Crow Arch Lane, Ringwood, Hants, BH24 1NZ
Directors: J.C.G. Chiverton. S.C. Wright. D. Phillips. D.M. Chorley



Doughty Engineering Ltd

Crow Arch Lane

Ringwood

Hampshire

BH24 1NZ

Telephone: +44 (0) 1425 478961

Email: sales@doughty-engineering.co.uk

Website: www.doughty-engineering.co.uk

Note: Whilst every effort has been made to ensure that the information contained within this manual is correct, Doughty Engineering does not accept any liability for errors or omissions. Specifications and technical data are intended for guidance purposes only and may vary.