

**COMPLETE STAND**

**PARTS LIST - PART NUMBERS IN BRACKETS**

**TOOLS NEEDED:  
2 X 13MM SPANNER  
8MM HEX DRIVE**

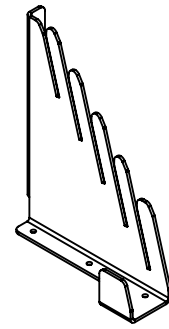

**X 1**  
(TH4848)

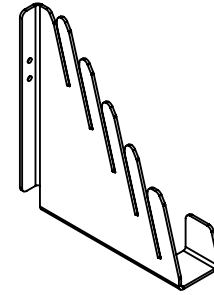

**X 1**  
(TH4849)

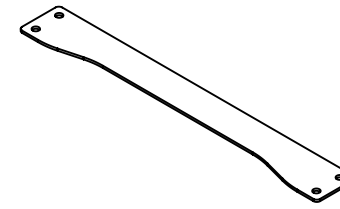

**X 1**  
(TH4851)

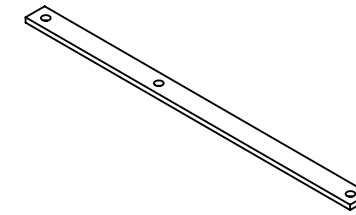

**X 2**  
(TH5060)

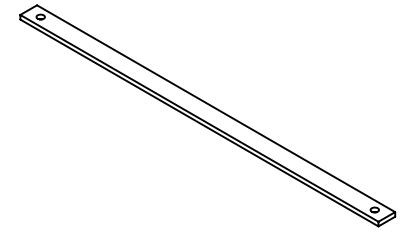

**X 2**  
(TH5059)

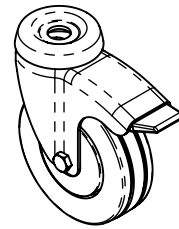

**X 2**  
(S3141)

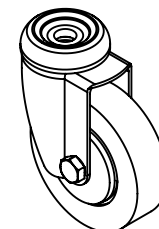

**X 2**  
(S3142)

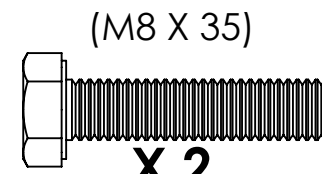

(M8 X 35)  
**X 2**  
(F811)

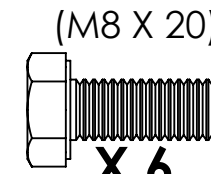

(M8 X 20)  
**X 6**  
(F2501)

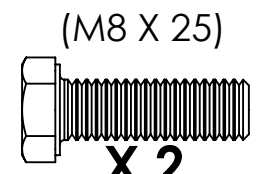

(M8 X 25)  
**X 2**  
(F2502)

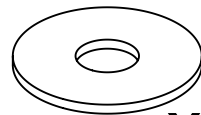

**X 4**  
(F1002)

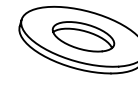

**X 4**  
(F891)



**X 6**  
(F671)

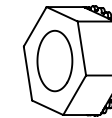

**X 10**  
(F936)

**WHEN FINISHED: ENSURE ALL FASTENERS ARE NOW FULLY TIGHTENED**



**TITLE**  
MINI TANK TRAP TROLLEY

**DWG NO**  
TANK TRAP SHEET 1 OF 3

**1. HAND TIGHTEN ALL FASTENERS UNTIL FINISHED**

**X 4** (M8 X 20)  
(F2501)

**X 4**  
(F891)

**X 4**  
(F936)

**X 1**  
(TH4848)

**X 1**  
(TH4849)

**X 1**  
(TH4851)

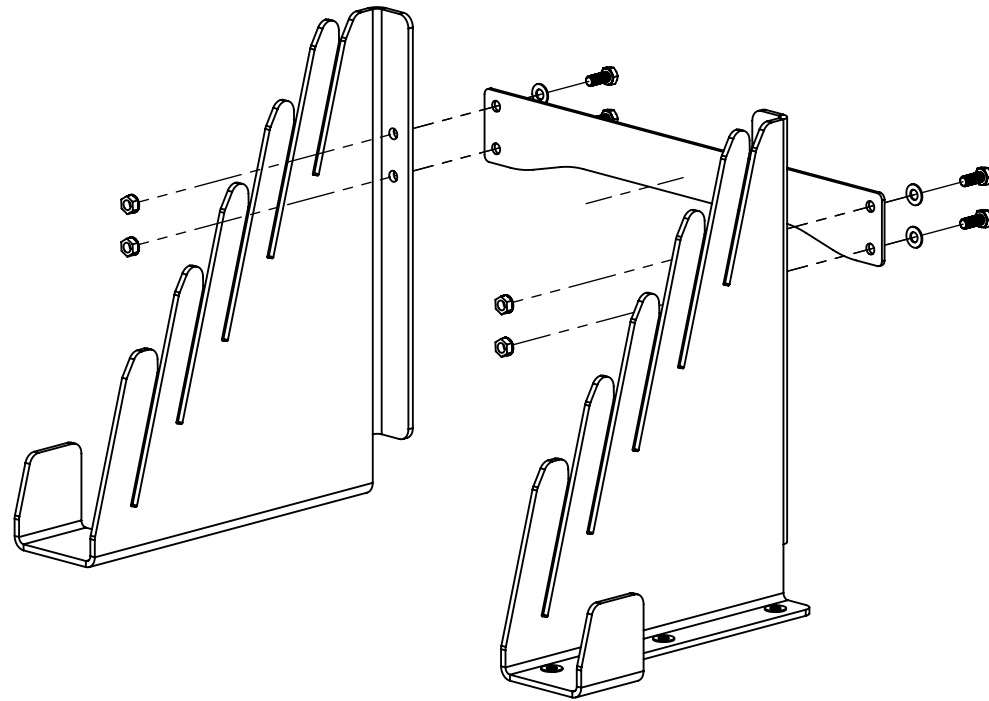

**2.**

**X 2**  
(TH5059)

**X 2**  
(TH5060)

**X 2**  
(F936)

**X 2**  
(F671)

(M8 X 25)  
**X 2**  
(F2502)

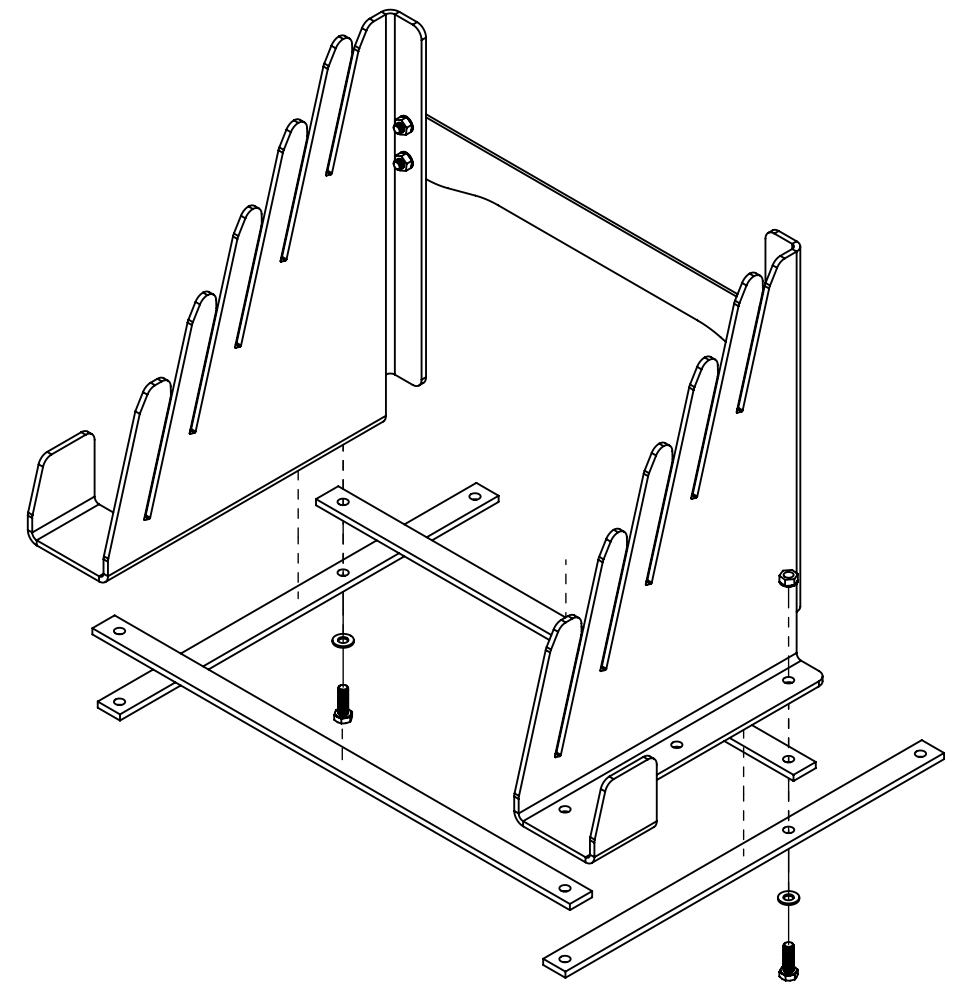

**3.**

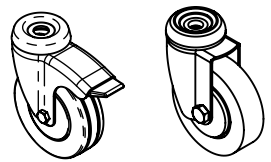

**X 2** (S3141) **X 2** (S3142)

**X 4**  
(F936)

**X 4**  
(F1002)

(M8 X 35)

**X 2**  
(F811)

(M8 X 25)

**X 2**  
(F2502)

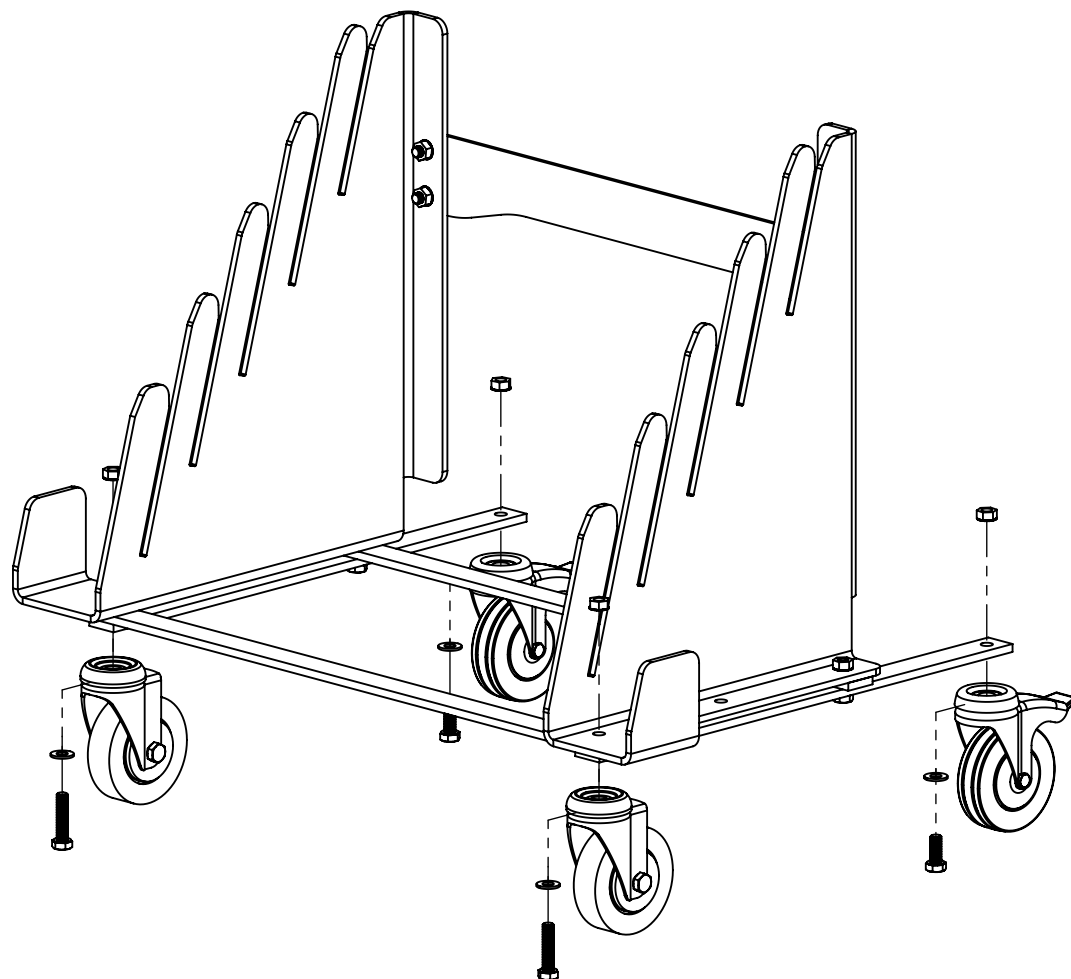

**4.**

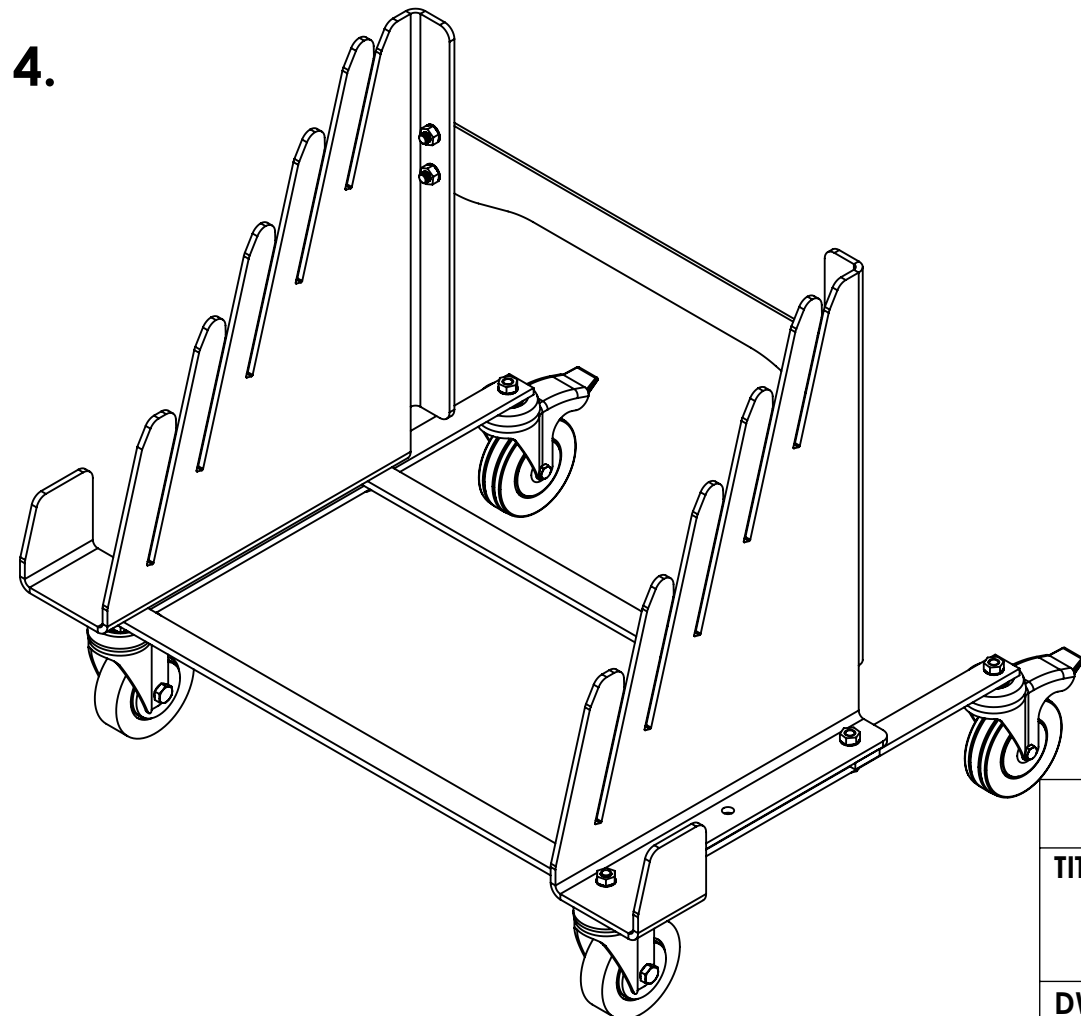

**DOUGHTY**

**TITLE**  
COMPACT TANK TRAP  
TRANSPORTER TROLLEY

**DWG NO**  
T54252 SHEET 2 OF 3

1.



POTENTIAL FINGER TRAP

i) START STACKING FROM THE FRONT OF THE RACK.

ii) ENSURE TANK TRAP IS FACING SLOT SIDE UP.

iii) PLEASE ENSURE TANK TRAP KNOB IS PARALLEL TO BASE PLATE.

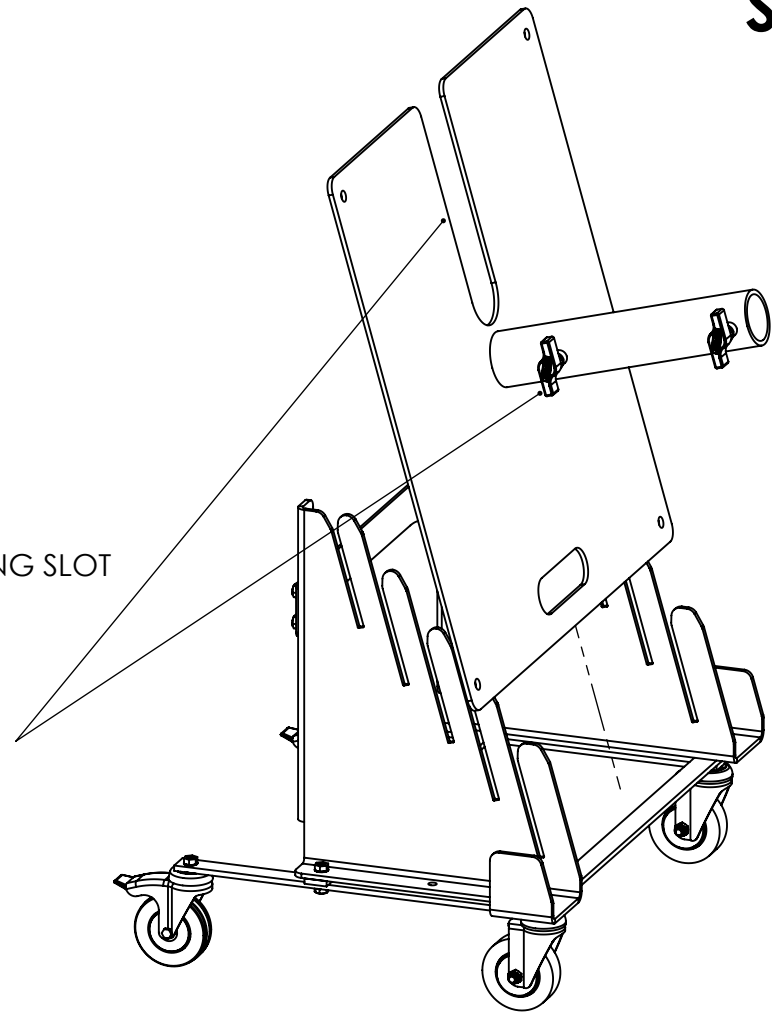

# STACKING INSTRUCTIONS

2.

i) LINE UP SECOND TANK TRAP RECEIVER WITH THE SLOT ON THE FIRST PLATE

ii) REPEAT STEP

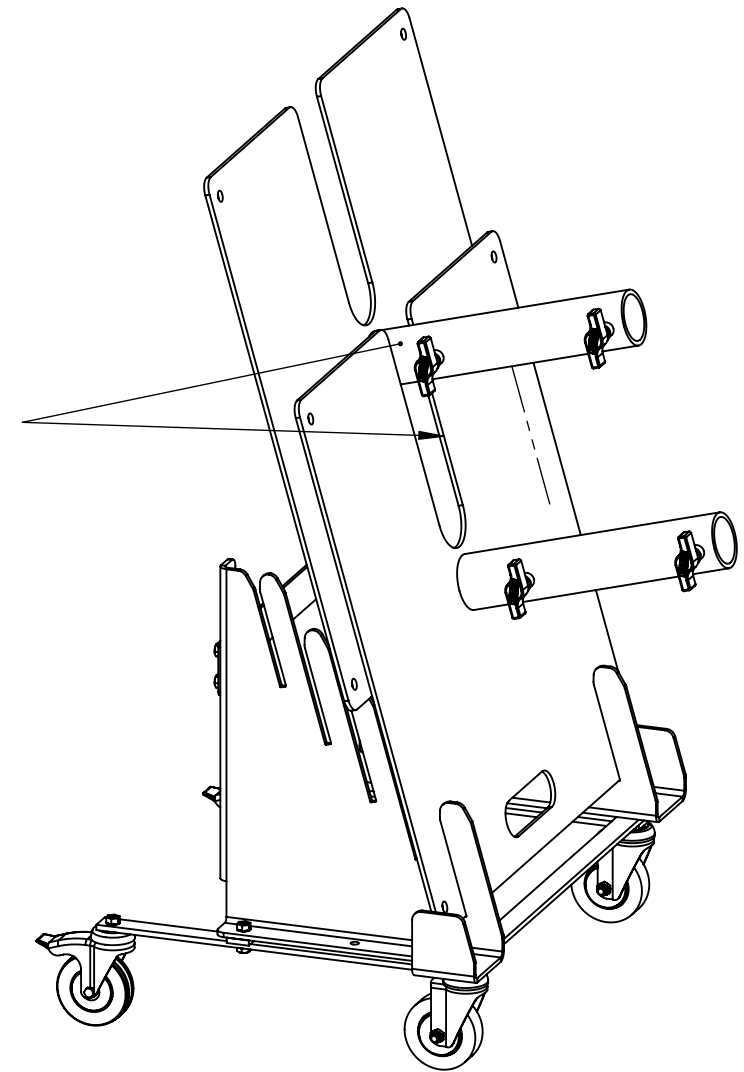

3.

i) THE BOTTOM KNOB OF THE FOURTH TANK TRAP SLOTS BETWEEN THE BASE PLATES OF THE 1ST & 2ND TANK TRAPS.

ii) ENSURE THE KNOB IS PARALLEL TO THE PLATE, OR IT WILL FOUL.

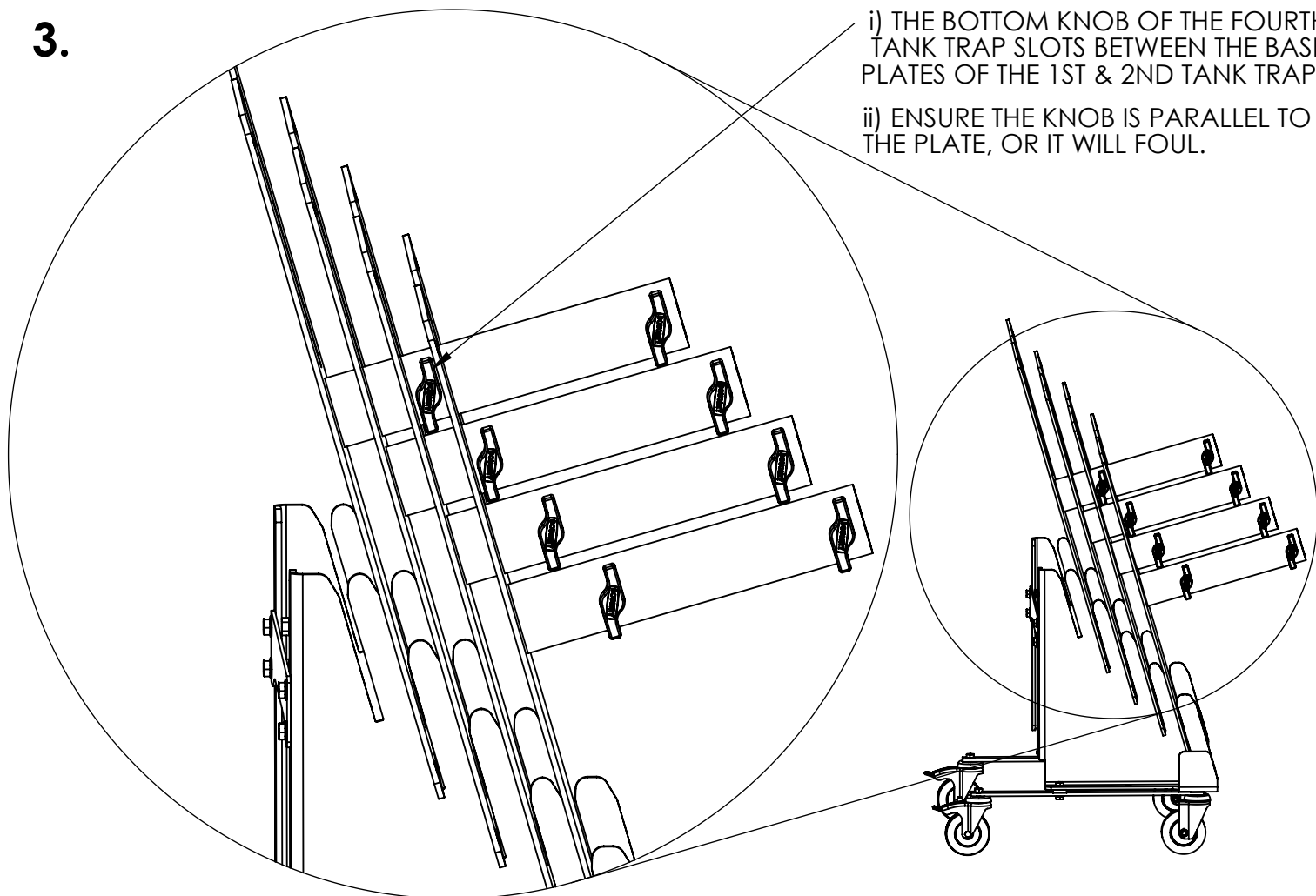

4.

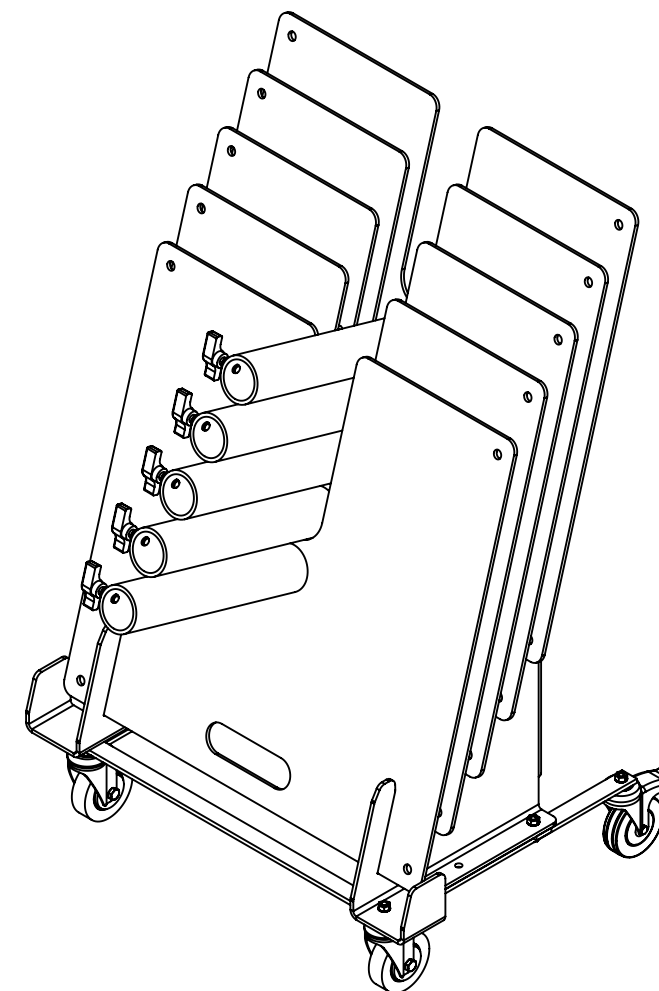

i) REPEAT STEP 3 FOR FINAL PLATE (BOTTOM KNOB WILL FIT BETWEEN SECOND AND THIRD BASE PLATES).

**DOUGHTY**

TITLE  
MINI TANK TRAP TROLLEY

DWG NO  
TANK TRAP SHEET 3 OF 3