



USER MANUAL

# Super Lightweight Clamps



Original Instructions

Part No's:

T58122 - T581501

# Loading Table

**Rated Load with a Safety Factor of 8:1 WLL1 DGUV/BGV C1 for Lifting Load**

**Rated Load with a Safety Factor of 4:1 WLL2 2006/42/ES for Static Load**

Part No.	Tube Diameter	Description	Finish	Accessory	WLL <sup>1</sup> (Kg) Lifting	WLL <sup>2</sup> (Kg) Static
T58122	Ø48-51mm	Super Lightweight Clamp	Polished	M10 x 30 Bolt and Wing Nut	50Kg	100Kg
T5812201	Ø48-51mm	Super Lightweight Clamp	Black	M10 x 30 Bolt and Wing Nut	50Kg	100Kg
T58123	Ø48-51mm	Super Lightweight Swivel Coupler	Silver	Two Clamps Joined	50Kg	100Kg
T5812301	Ø48-51mm	Super Lightweight Swivel Coupler	Black	Two Clamps Joined	50Kg	100Kg
T58124	Ø48-51mm	Super Lightweight Hanging Clamp	Silver	M10 Eye Nut	50Kg	100Kg
T5812401	Ø48-51mm	Super Lightweight Hanging Clamp	Black	M10 Eye Nut	50Kg	100Kg
T58125	Ø48-51mm	Super Lightweight Beamer Clamp	Silver	16mm Beamer Spigot	50Kg	100Kg
T5812501	Ø48-51mm	Super Lightweight Beamer Clamp	Black	16mm Beamer Spigot	50Kg	100Kg
T58130	Ø48-51mm	Super Lightweight Panel Clamp	Silver	None	N/A	N/A
T5813001	Ø48-51mm	Super Lightweight Panel Clamp	Black	None	N/A	N/A

## Rated Load with a Safety Factor of 8:1 WLL1 DGUV/BGV C1 for Lifting Load

## Rated Load with a Safety Factor of 4:1 WLL2 2006/42/ES for Static Load

Part No.	Tube Diameter	Description	Finish	Accessory	WLL <sup>1</sup> (Kg) Lifting	WLL <sup>2</sup> (Kg) Static
T58132	Ø25mm to Ø48-51mm	Super Lightweight to Atom Swivel Coupler	Polished	Two Clamps Joined	50Kg	100Kg
T5813201	Ø25mm to Ø48-51mm	Super Lightweight to Atom Swivel Coupler	Black	Two Clamps Joined	50Kg	100Kg
T58133	Ø32mm to Ø48-51mm	Super Lightweight to Atom Swivel Coupler	Silver	Two Clamps Joined	50Kg	100Kg
T5813301	Ø32mm to Ø48-51mm	Super Lightweight to Atom Swivel Coupler	Black	Two Clamps Joined	50Kg	100Kg
T58134	Ø35mm to Ø48-51mm	Super Lightweight to Atom Swivel Coupler	Silver	Two Clamps Joined	50Kg	100Kg
T5813401	Ø35mm to Ø48-51mm	Super Lightweight to Atom Swivel Coupler	Black	Two Clamps Joined	50Kg	100Kg
T58135	Ø38mm to Ø48-51mm	Super Lightweight to Atom Swivel Coupler	Silver	Two Clamps Joined	50Kg	100Kg
T581501	Ø38mm to Ø48-51mm	Super Lightweight to Atom Swivel Coupler	Black	Two Clamps Joined	50Kg	100Kg

The Super Lightweight Clamp range consists of various couplers used to lift loads or make structural connections. Clamps are used in the entertainment market. They can be used for permanent support structures in places of entertainment such as museums, event venues, theatres etc.

Lifting loads is inherently dangerous so Super Lightweight Clamps are strictly for professional use only. Only competent persons are permitted to install and use Super Lightweight Clamps. A competent person in this respect is an individual with relevant technical education, training and/or experience enabling him or her to perceive risks and to avoid hazards occurring during use of a product.

The load capacity differs depending on the model and the safety factor required. Clamps are suitable to fit steel and aluminium tubes of diameters ranging from 48mm to 51mm depending on the model. Most Clamps are available in silver (polished aluminium) or black powder coating. Special attention has been taken to safety. Therefore the TUV test certificates indicate multiple working loads. Depending on the application or local applicable legislation max working load can be chosen.

Clamps can be judged as a lifting accessories under the EU machine Directive 2006/42/EC as well as German DGUV17 for lifting and holding loads above persons. They can also be used as a joining part in constructions. For this application no harmonised standard is available and no CE Declaration of Performance can be provided.

All communications will be carefully considered for future printings of this manual and changes to our products. Some models of clamps are composed of different elements each with an individual Working Load. The lowest of the working loads determines the overall strength and thus shall be used as max working Load for the application.

When Super Lightweight Clamps form part of a lifting machine or lifting system, the lifting machine or system shall be tested and marked with its WLL and appropriate certification issued. The resulting forces in the structure attached shall be verified before applying a load.



### **Warning**

**Check local legislation for the application of use and adapt the use where ever necessary.**

The intended use of clamps is to be used as a lifting accessory to hang loads or create a connection between structural elements. Loads can be, but not limited to, lighting fixtures, video projectors, sound systems and stage sets. Structural elements can be pipes, trusses, tubular frame works or lifting brackets.

Any use other than that mentioned is considered to be a case of misuse. The user/operator and not the manufacturer shall be liable for any damage or injury resulting from such cases of misuse. The use of clamps for scaffolding purposes under EN74 is explicitly excluded from the intended use.

- The clamps can be operated in -20° Celsius up to +60° Celsius.
- When used permanently outdoors it is advised to use the versions with stainless steel hardware in order to avoid galvanic corrosion.
- For salt water environments, please use our All Weather Clamp range.
- Super Lightweight Clamps shall only be used on steel or aluminium tubes or bars.
- When Super Lightweight Clamps are used as part of an outdoor lifting system special factors such as ground condition and profile, wind loading, water accumulation on temporary structures and other criteria shall also be taken into account.
- The use of clamps is the sole responsibility of the user.
- To use the clamps the user must also observe the safety regulations.
- All persons who use and service this device have to be acquainted with this manual and must be informed about its potential hazards.
- It is also imperative to observe the local accident prevention regulations and/or occupational health and safety regulations.
- Care must be taken when used in conjunction with thin wall truss.
- The manufacturer is not liable for indirect consequential damage and financial loss. The manufacturer shall not be liable for any changes made to the device nor for any damage resulting from such changes.

TYPICAL SUPER LIGHTWEIGHT CLAMP

Dimensions in mm

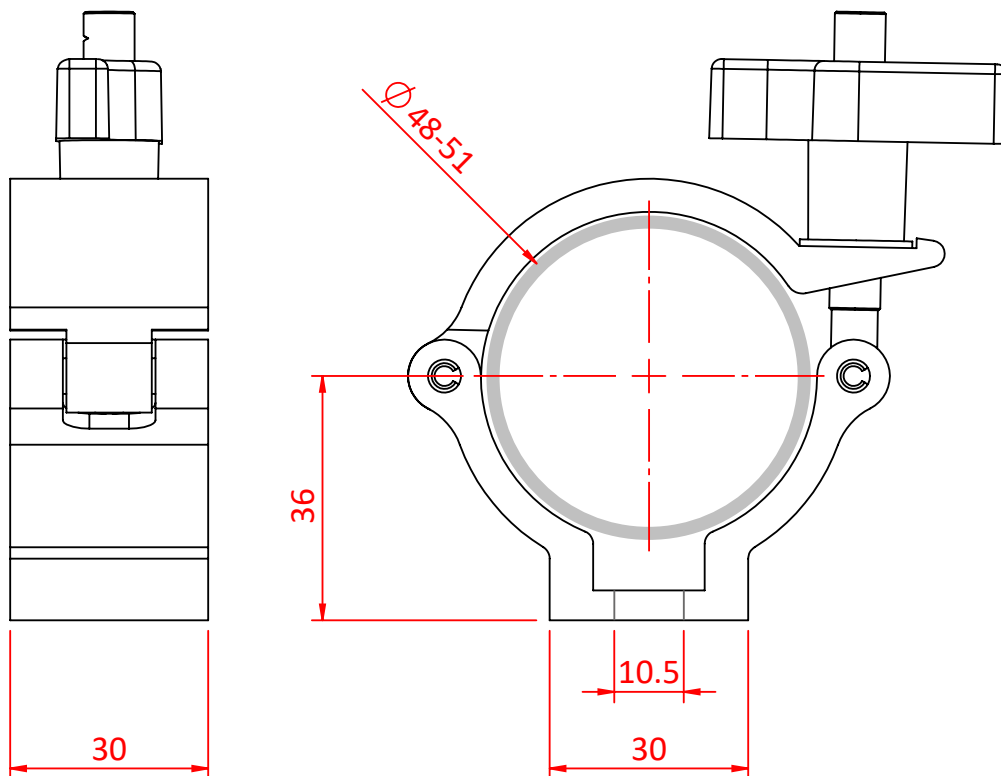

TYPICAL SUPER LIGHTWEIGHT SWIVEL CLAMP

Dimensions in mm

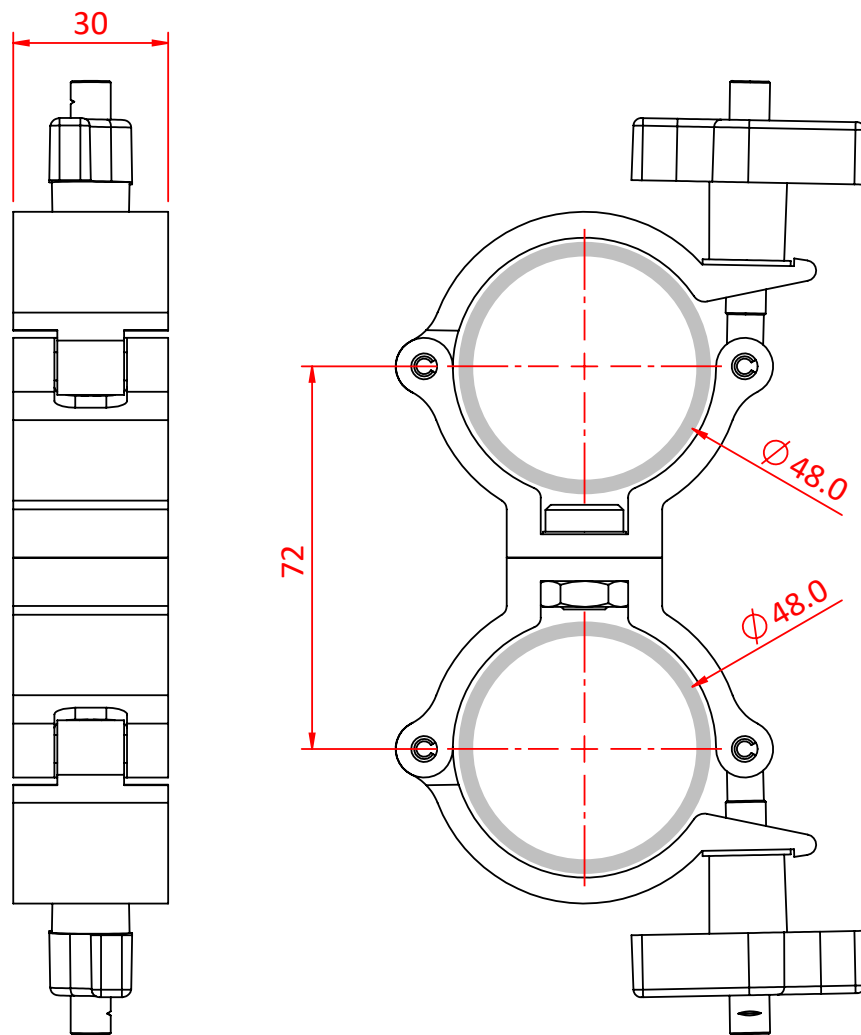



TYPICAL SUPER LIGHTWEIGHT HANGING CLAMP

Dimensions in mm

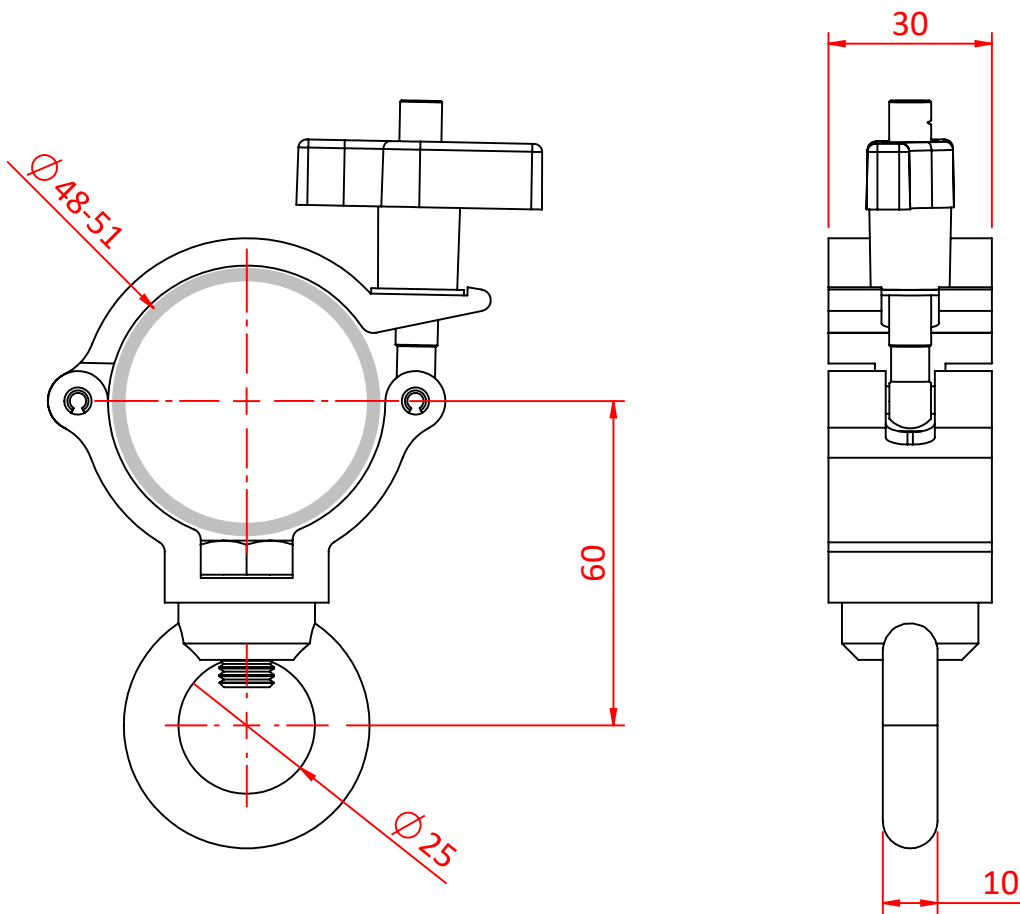

TYPICAL SUPER LIGHTWEIGHT BEAMER CLAMP

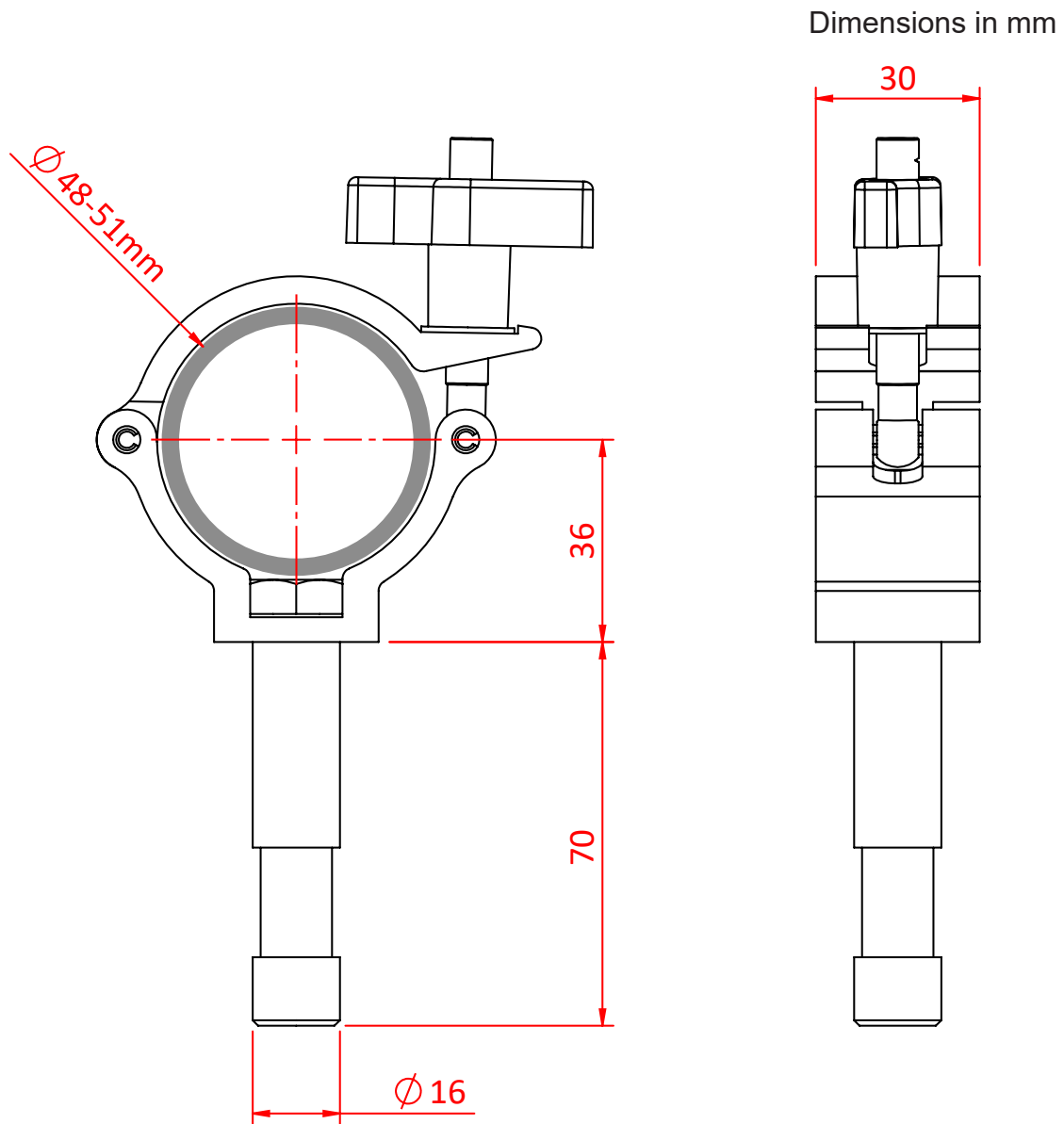

TYPICAL SUPER LIGHTWEIGHT PANEL CLAMP

Dimensions in mm

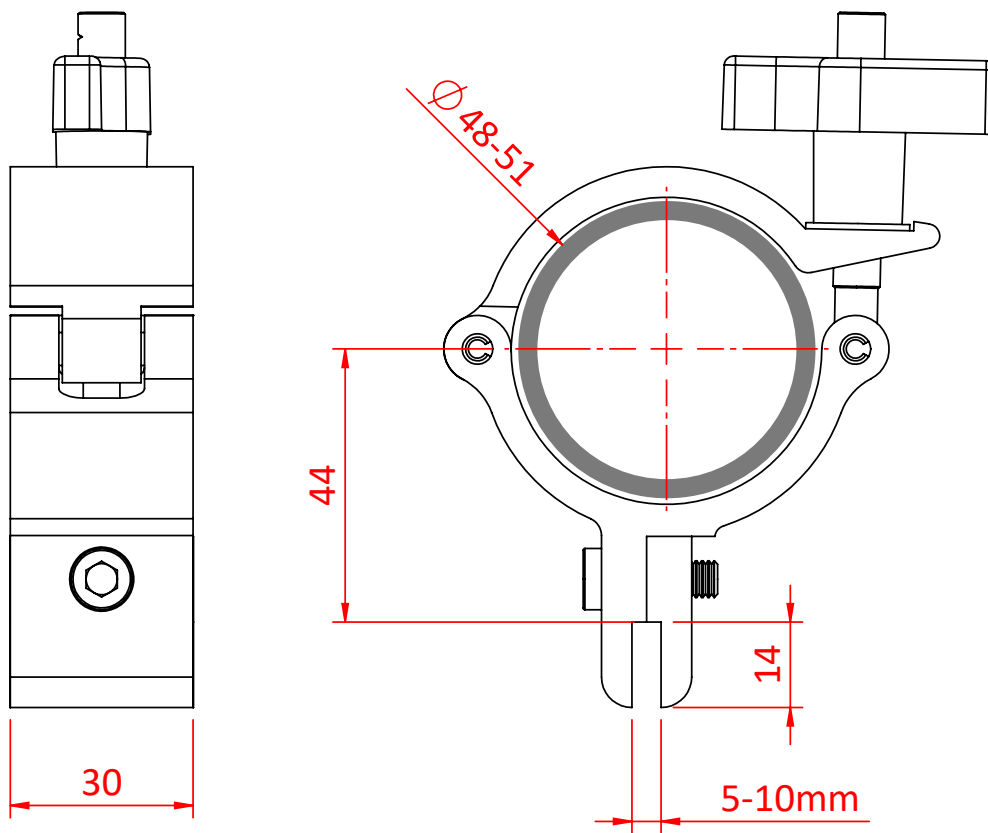

TYPICAL SUPER LIGHTWEIGHT TO ATOM SWIVEL COMBO  
Ø25MM TO Ø48-51MM

Dimensions in mm

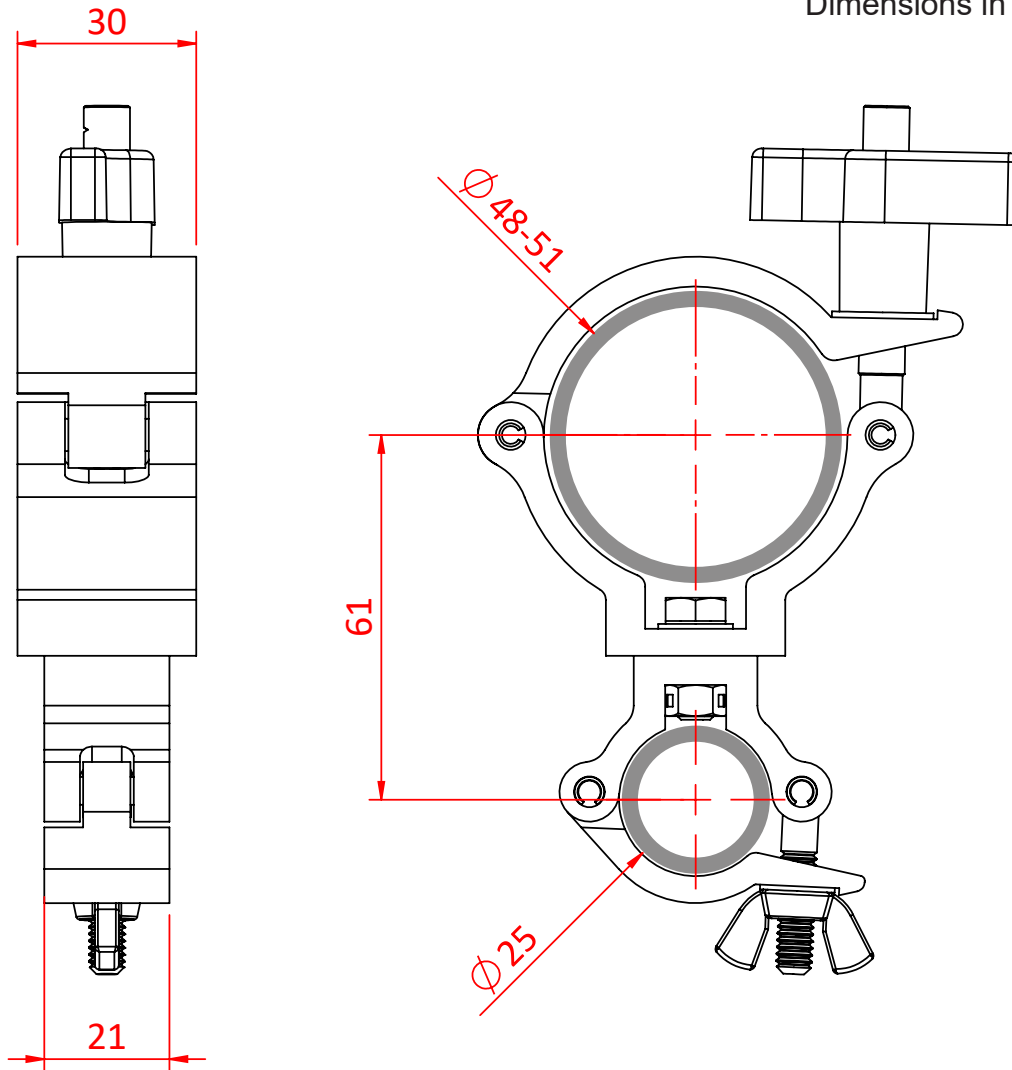

TYPICAL SUPER LIGHTWEIGHT TO ATOM SWIVEL COMBO  
Ø32MM TO Ø48-51MM

Dimensions in mm

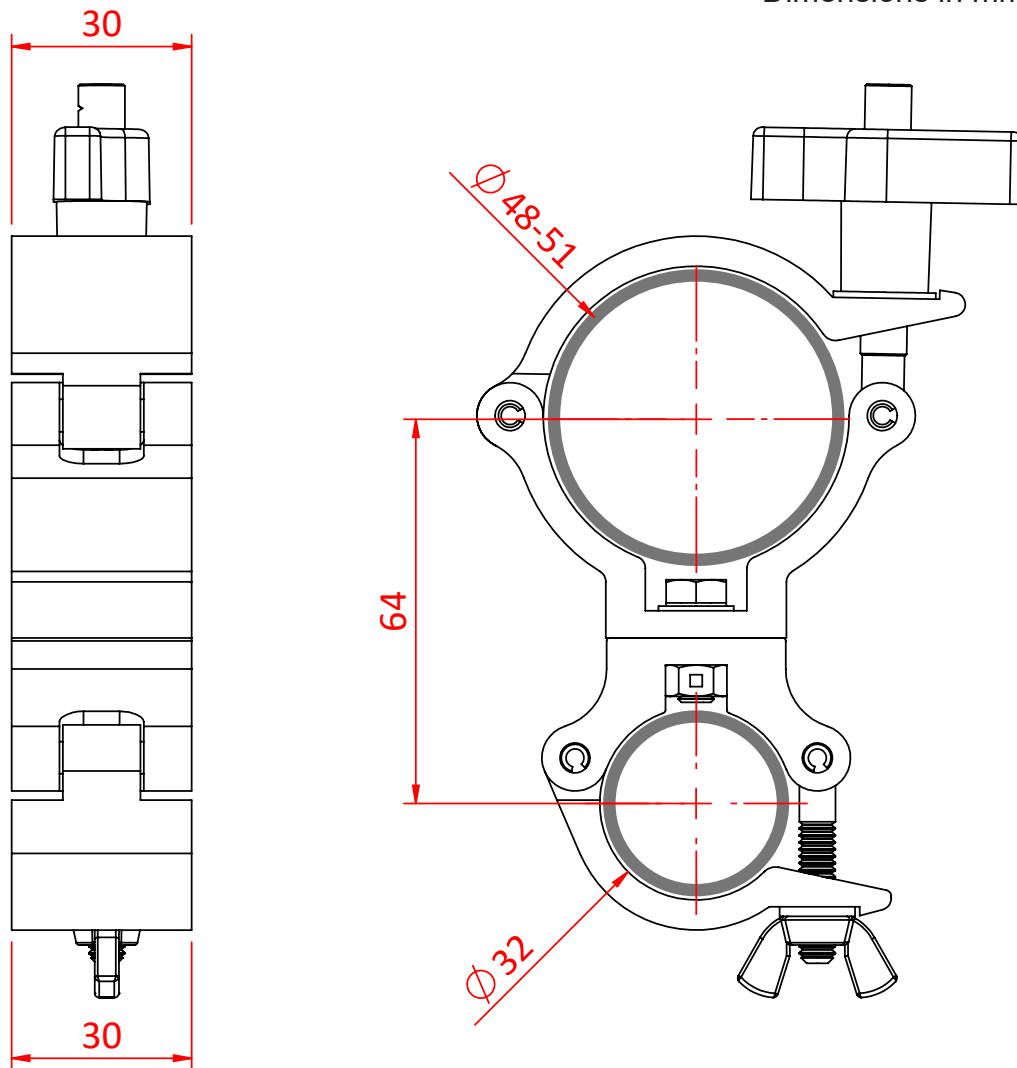

TYPICAL SUPER LIGHTWEIGHT TO ATOM SWIVEL COMBO  
Ø35MM TO Ø48-51MM

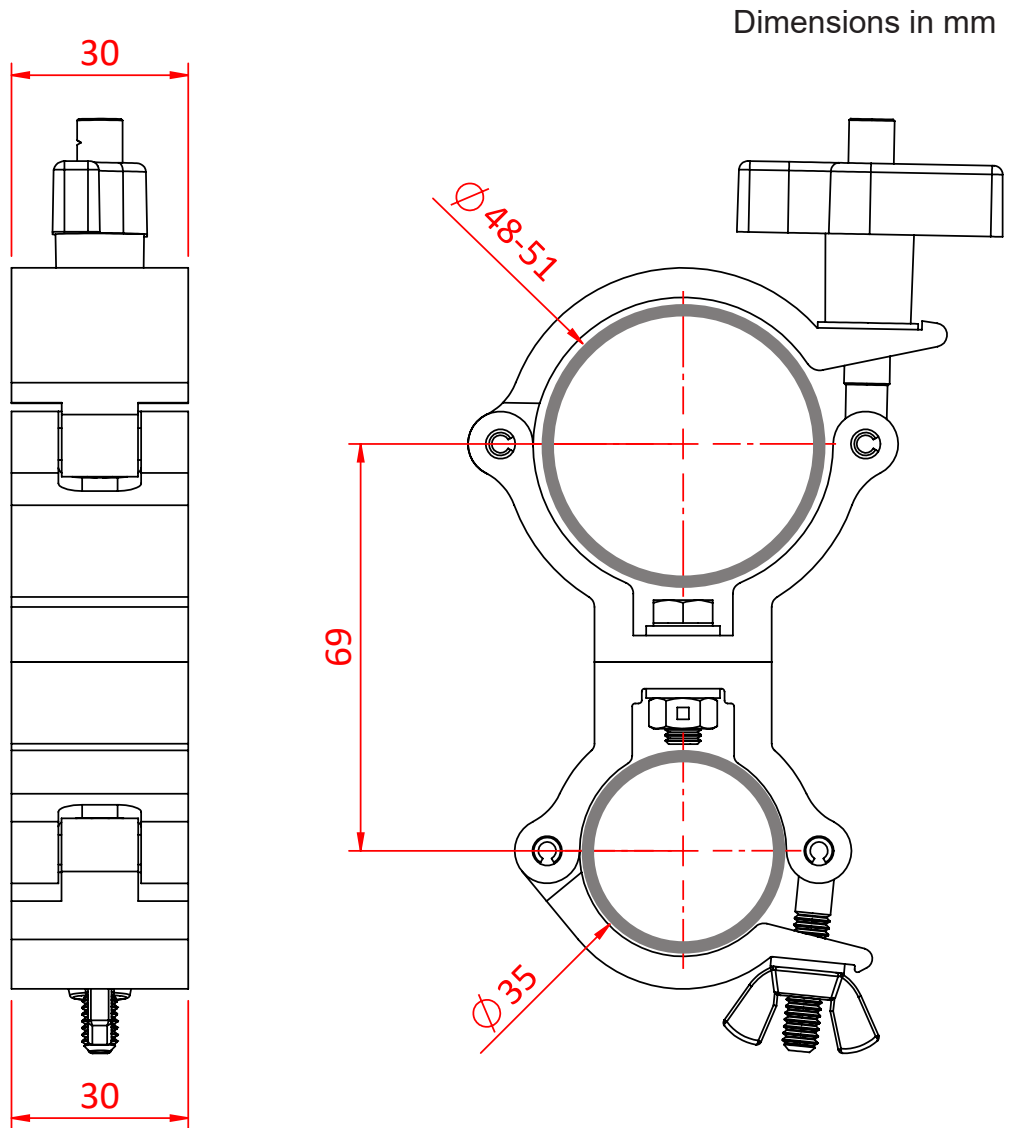

TYPICAL SUPER LIGHTWEIGHT TO ATOM SWIVEL COMBO  
Ø38MM TO Ø48-51MM

Dimensions in mm

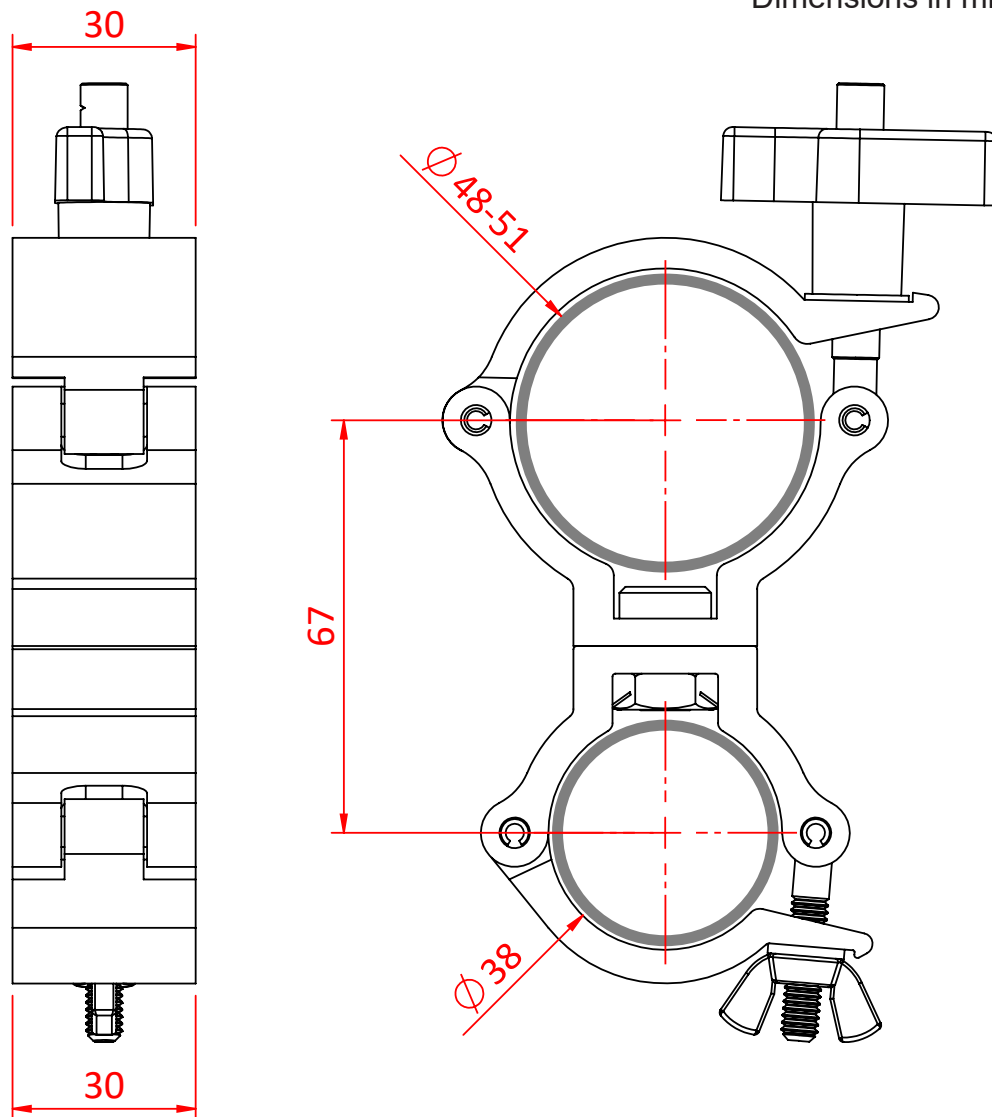



TYPICAL SUPER LIGHTWEIGHT CLAMP LABEL

*Part No* — **T58122 - Ø48-51mm** — *Tube Diameter*  
*Works Order No* — **Wo. 2021001**

**DOUGHTY**

*Post Code* — **BH24 1NZ, UK**

*TUV Mark* —   — *Read Instructions*

 — *CE mark*  
*Year of Manufacture* — **24**

*Working Load Limit* — **WLL 100kg**



**The following modifications are allowed to be executed by third parties:**

### **Painting:**

- To paint a clamp, cover all bolts and nut with tape.
- Use blasting to roughen the surface and to degrease the coupler.
- Use a wet-paint or powder coating paint system to colour the part.

### **Safety Instructions:**

For health and safety reasons people assembling, disassembling, transporting, maintaining and cleaning clamps should wear adequate Personal Protection Equipment such as, but not limited to: gloves, hard hats and safety shoes. In line with the use of PPE organisational measures may need to be implemented to keep the area beneath installations clear of personnel.

- Clamps shall be solely used for the range of pipe diameters as stated on the Clamps.
- Do not exceed the working load limit engraved on the Clamps.
- Make sure the resulting forces on the supporting structure are approved by a competent person.
- All loads imposed shall be considered, e.g. dynamic forces caused by the lifting machinery.
- Nuts and bolts shall be tightened by means of a tool in such a manner they cannot be released by man power.
- When loads are using electrical power, equip-potential bonding shall be put in place.
- Clamps shall be inspected by a competent person as often as required but with a minimum of once a year.
- Inspect equipment before every use. Damaged Clamps shall be taken out of service.
- Maintenance and repairs can be undertaken only by authorised personnel. If in any doubt contact the manufacturer.
- Do not throw Clamps.



### Warning

The working load engraved on the clamp is solely for a straight pull between the supporting pipe and connection point on the clamp.

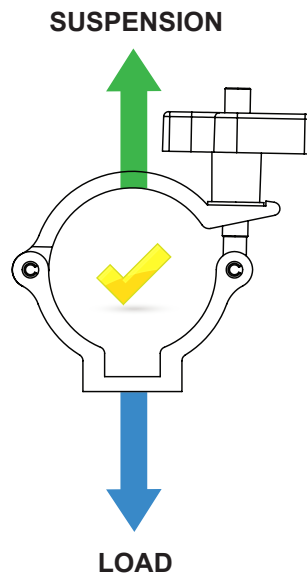

### Warning

The methods of suspension that are shown below creates torsional forces, influencing the stability of the supporting structure and lowers the working load of the clamp. This needs to be checked by a competent person.

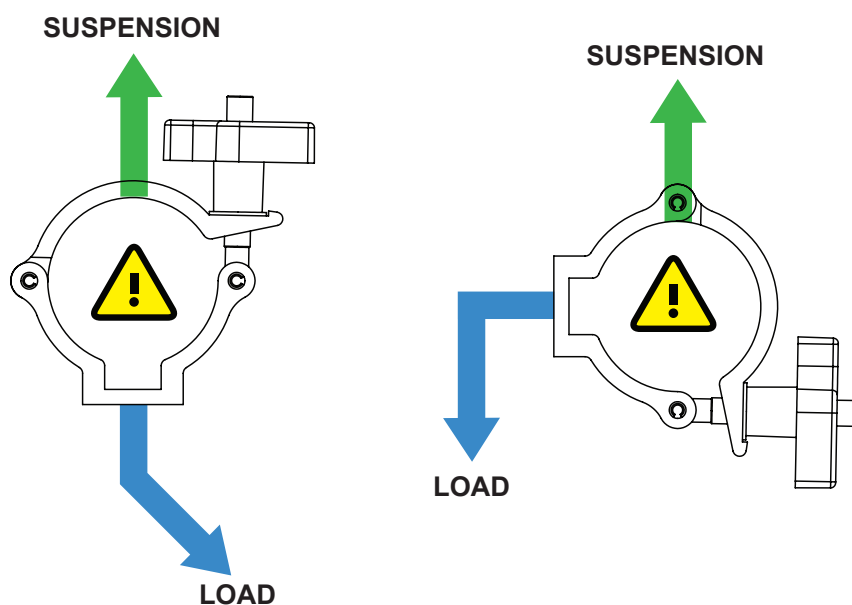



### Warning

Using clamps where the direction of the load is parallel to the tube depends on, but not limited to, contact surface, material, friction resistance and the applied torque to the clamps wingnut/nut. This type of application significantly reduces the stated WLL and should be used with extreme caution.

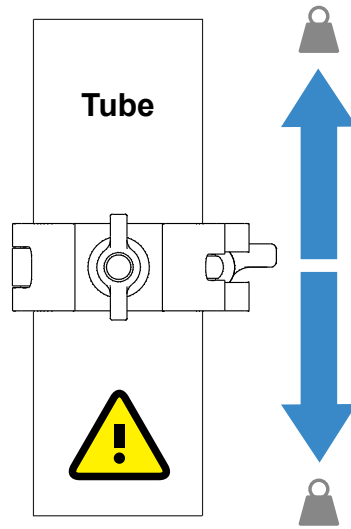

### Warning

Do not use fixings that, when tightened, will contact the tube or barrel on which the clamp is fixed, as highlighted below.

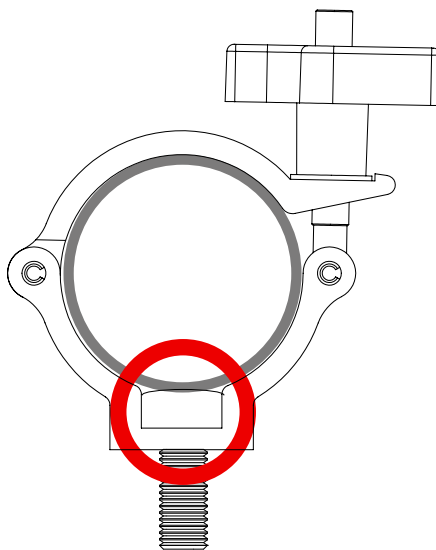

### **CLAMPS USED AS A LIFTING ACCESSORY:**

**2006/42/EC** - Machinery Directive.

**DGUV Rules 115-002** - Regulations for stages and studios (Formerly known as BGVc1)

**DGUV Information 215-313** - Safety at productions and events for television, radio, film, theatre, exhibitions: Loads above persons (Formerly known as BGI 810-3)

**BS7906-1:2005** - Lifting equipment for performance broadcast and similar applications. Part 1 specifications for the design and manufacture of above stage equipment.

### **TRANSPORT AND STORAGE**

- Due to the relatively high self-weight it is advised to keep storage bins as small as possible in such a manner they can be lifted by one person. Local legislation for maximum load to be lifted by persons shall be adhered to.
- Before clamps are put into storage they shall be checked for defects. Defective clamps shall be clearly marked and put aside in such a way they cannot be re-used.
- Put the lid and eye bolt together and hand tighten. This way bolts will not get lost during transport.
- Ensure the product is stored and kept in a dry, ventilated environment to avoid corrosion.
- Do not store aluminium clamps in steel bins.
- Use appropriate packaging to prevent damage to parts and threads when transporting clamps.

Super Lightweight Clamps are used to suspend or make structural connections between truss or barrel and a variety of objects using an M10 Fixing.

Super Lightweight Couplers are used for rigging two sections of truss or barrel together. The couplers consist of two clamps bolted together. In the case of the swivel coupler the two clamps are free to rotate relative to each other.

Super Lightweight Hanging Clamps are commonly used to secure rope directly or via shackles, Karabiners hooks etc.

Super Lightweight Beamer Clamps are used for suspending items with a 16mm receiver.

Super Lightweight Panel Clamps are designed to hold panels with a thickness between 5-10mm.

To install, attach the clamps to their respective barrel or truss following the instructions below:

1. Open the lid of the clamp.
2. Fold the eye bolt and lid aside.
3. Hang the clamp in the desired position. Tighten the bolt before the load is fully supported
4. Tighten the wingnut/nut/bolt by hand only.
5. Use a secondary safety if legislation requires.



### Warning

**Over tightening the nut or bolt might lead to permanent deformation of the tubes to which they are attached.**

## COMMISSIONING

- The clamp is not intended to serve as a means to secure electrical bonding and any fixtures must be grounded in accordance with accepted electrical practices.
- Do not use clamps in the immediate vicinity of pyrotechnics.
- If used in an outdoor environment, the support structure must be fitted with earth protection against lightning.
- Before applying a load check that all connections are properly made.
- Before lifting check that all connections are still correct.
- Check if all parts are in good order.

## DISASSEMBLY INSTRUCTIONS

- Take the weight off the clamp.
- Release the nut and fold the eye bolt aside.
- Open the lid and fold aside.
- Remove the load.
- Check if the clamp is in good order.
- If not, mark them clearly and put aside.

Table 1	Inspection Level			Items to be Inspected					
	Initial	Regular	Periodic	Lid	Body	Eyebolt	Nut	Roll Pin	ID
Missing Parts	Y	Y	Y						Y
Holes	Y	Y	Y	Y	Y				
Abrasion	Y	Y	Y	Y	Y			Y	
Corrosion			Y	Y	Y	Y	Y	Y	
Deformation	Y	Y	Y	Y	Y	Y	Y	Y	
Excessive Wear		Y	Y		Y	Y	Y	Y	
Cracks	Y	Y	Y	Y	Y	Y	Y	Y	

**INITIAL INSPECTIONS** - When first acquired, whether they are new or used, clamps should be inspected in accordance with Table 1 and a record of the inspection maintained.

**REGULAR INSPECTIONS** - Regular visual inspections should be carried out in accordance with Table 1. Regular inspections should be performed by a competent person and should be carried out prior to each incident of use.

**PERIODIC INSPECTIONS** - Periodic visual inspections should be carried out in accordance with Table 1 and a record of the inspections maintained. Periodic inspections should be performed by a competent person and should be conducted at least once each year or in accordance with an inspection routine established by a qualified person. Clamps which are subject to any accident must be inspected according to the requirements per periodic inspection and in accordance with Table 1.



### INSPECTION FREQUENCY

**CLAMPS IN REGULAR SERVICE** - Clamps in regular service should be subjected to regular and periodic inspections.

**PERMANENT INSTALLATIONS, STATIONARY** - Periodic inspections should be carried out on all clamps that are permanently installed in a stationary (not moving) configuration. The frequency of inspections should be determined on the basis of the prevalent conditions.

**PERMANENT INSTALLATIONS, MOVING** - Periodic inspections should be carried out every three months, or in accordance with an inspection routine established by a qualified person, on all clamps that are installed in a permanent configuration where movement of the truss system is an integral part of use.

**RECORDS** - Records of initial inspections and periodic inspections should be kept by the owner for each clamp and should be signed and dated by the person carrying out the inspections.



## Safety Instructions

Although under normal use and environmental circumstances, clamps need little maintenance, for safety reasons, all parts must be checked regularly for damage, cracks and corrosion.

### NOTICE

Super Lightweight Clamps shall be checked in compliance with the local law by a competent person. Checking shall take place as often as required but at a minimum of once a year. If in doubt contact the manufacturer.

- Approved personnel must carry out a visual and functional test before every useage.
- Check all components for damage and corrosion. Damaged and corroded parts shall be exchanged with like for like approved replacement parts.
- Burrs and sharp edges shall be removed using fine sandpaper or a file. DO NOT use any mechanical abrasive machine to remove sharp edges from the couplers.
- Maintenance and repairs must only be carried out by a competent person. If in doubt, contact the manufacturer.
- Only use hot water and soap to remove dirt from Super Lightweight Clamps – DO NOT use abrasive fluids.
- Do not re-zinc plate steel parts.
- Approved personnel must carry out more detailed inspection and testing of the product on a regular basis depending on the usage of the product.
- Written records should be kept from the date the product was put into operation.



### Warning

- The installer/operator must read and understand the User Manual before using the equipment.
- Operators shall be adequately instructed and fully understand the safe use of the equipment before use.
- Failure to carry out maintenance as necessary, including the replacement of parts to the correct standard could render this equipment unsafe and the manufacturer cannot accept any responsibility in this respect.
- DO NOT modify the equipment as this could lead to a critical failure.
- DO NOT use this equipment for a purpose that it is not intended. This could lead to a failure of the equipment and a risk of falling objects.

The following faults could be an indication of overload or misuse. Remove those couplers from service.

- Deformation of the lid (see diagram).
- Nuts which cannot be turned by hand.
- Eyebolts which do not swivel properly.
- Lids which do not swivel properly.
- Clamp does not fit around the pipe.

### Typical Deformation Examples

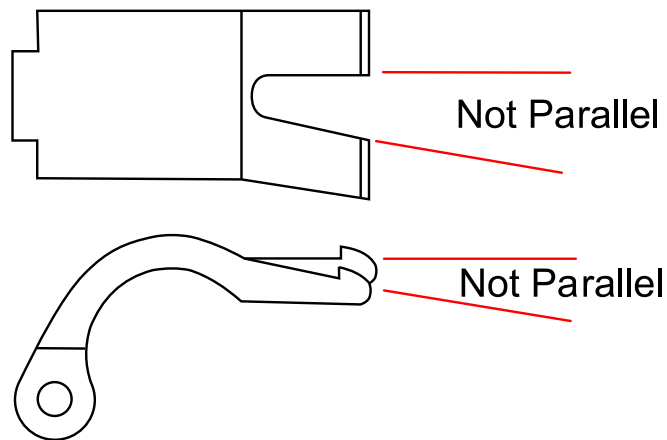

### REPAIRS AND REPLACEMENT OF PARTS

If the Mammoth Coupler is damaged, contact the manufacturer.

### DISPOSAL

Products that are no longer needed can be scrapped. Preferably remove all steel parts, store part separately before offering them to a scrapping company. The following alloys are used:

- Aluminium ENAW 6082
- Steel 8.8
- Stainless 304

### WARRANTY

- For a period of 12 months we undertake to repair, free of charge any damage attributable to faulty materials or workmanship, provided that the appliance is forwarded, freight paid, to our works or one of the Doughty appointed service agents.
- The guarantee-period begins on the day of the delivery, proven by a purchase receipt like an invoice or delivery note or their copies.
- The guarantee only is applicable for new equipment.
- The guarantee does not cover damage due to transport damage, negligent handling, overload or parts subject to normal wear and tear. Nor damages that originate from a case of misuse because of non-observance the instructions in this manual.
- The fitting of non-original replacement parts or modifications of design by third parties invalidates the guarantee.
- Guarantee repairs do not renew nor extend the guarantee-period.
- In case of a claim under the guarantee or spare part requirements please contact your Doughty service agent.
- The manufacturer is not liable for indirect consequential damage or financial loss.
- The manufacturer is not liable for any changes made to the coupler or for any damage resulting from such changes.



Product Data Sheet

# Super Lightweight Half Coupler



A high tensile super lightweight half coupler Slotted to hold captive an M10 Nut or Bolt	
<b>Part Nos</b>	T58122 - Polished T5812201 - Powder Painted Satin Black
<b>Tube Diameter</b>	Ø48 - 51mm (1.89" - 2.01")
<b>Materials</b>	Main Body - AW6082 T6 Aluminium Roll Pins - Stainless Steel Eyebolt - Grade 8.8
<b>Max Tightening Torque</b>	Hand-tight Only
<b>Fixings</b>	Supplied with M10x30 Bolt / Wing Nut
<b>WLL</b>	100Kg
<b>Weight</b>	0.18Kg (0.4 lbs)
<b>Factor of Safety</b>	5:1
<b>Approval</b>	TÜV Approved

Dimensions in mm

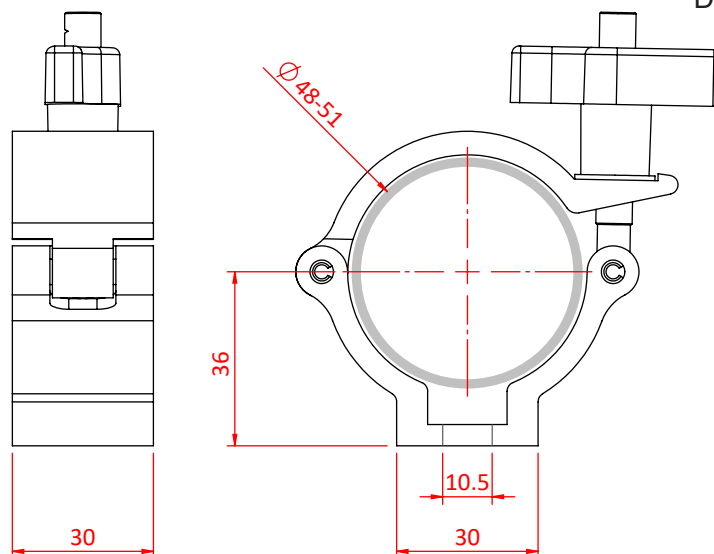

Doughty Engineering Ltd - Crow Arch Lane, Ringwood, Hampshire, BH24 1NZ, UK  
+44 (0) 1425 478961, sales@doughty-engineering.co.uk - www.doughty-engineering.co.uk



Product Data Sheet

# Super Lightweight Swivel Coupler

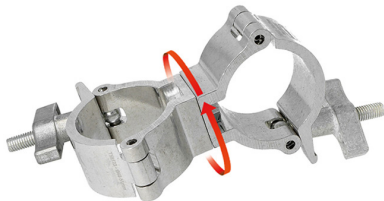

A pair of 360° swiveling super lightweight half couplers which provide a firm fixing between two bars	
<b>Part Nos</b>	T58123 - Polished T5812301 - Powder Painted Satin Black
<b>Tube Diameter</b>	Ø48 - 51mm (1.89" - 2.01")
<b>Materials</b>	Main Body - AW6082 T6 Aluminium Roll Pins - Stainless Steel Eyebolt - Grade 8.8
<b>Max Tightening Torque</b>	Hand-tight Only
<b>Fixings</b>	N/A
<b>WLL</b>	100Kg
<b>Weight</b>	0.29Kg (0.64 lbs)
<b>Factor of Safety</b>	5:1
<b>Approval</b>	TÜV Approved

Dimensions in mm

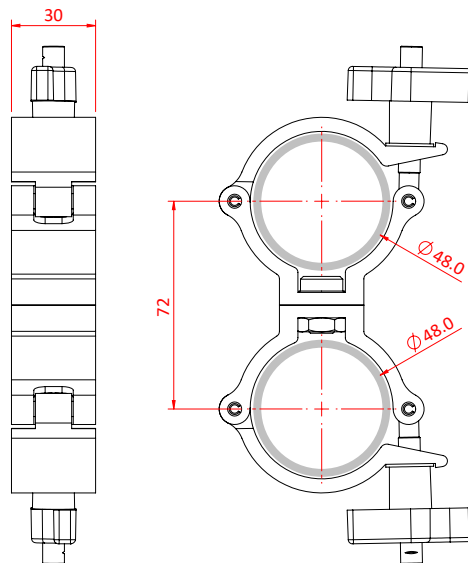

Doughty Engineering Ltd - Crow Arch Lane, Ringwood, Hampshire, BH24 1NZ, UK  
+44 (0) 1425 478961, sales@doughty-engineering.co.uk - www.doughty-engineering.co.uk



Product Data Sheet

# Super Lightweight Hanging Clamp



A super lightweight half coupler fitted with an eye nut.	
<b>Part Nos</b>	T58124 - Polished T5812401 - Powder Painted Satin Black
<b>Tube Diameter</b>	Ø48 - 51mm (1.89" - 2.01")
<b>Materials</b>	Main Body - AW6082 T6 Aluminium Roll Pins - Stainless Steel Eyebolt - Grade 8.8 Eye Nut - C15E Steel
<b>Max Tightening Torque</b>	Hand-tight Only
<b>Fixings</b>	M10 Eye Nut
<b>WLL</b>	100Kg Vertical Load
<b>Weight</b>	0.18Kg (0.40 lbs)
<b>Factor of Safety</b>	5:1
<b>Approval</b>	TÜV Approved

Dimensions in mm

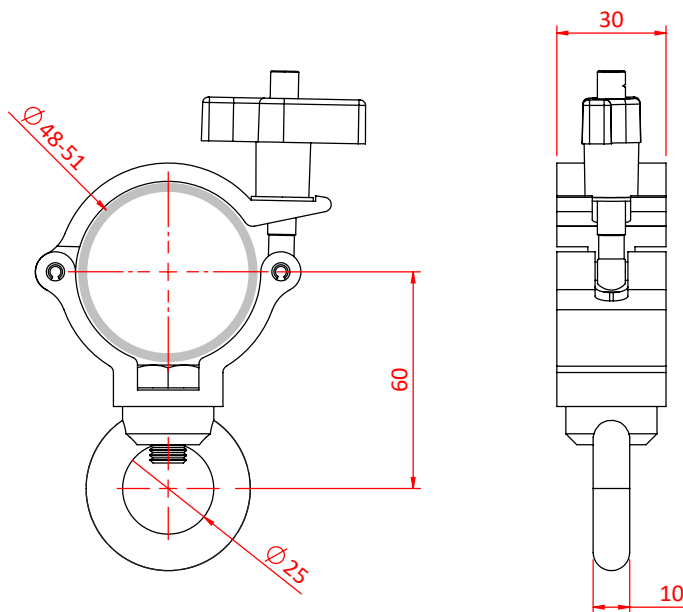

Doughty Engineering Ltd - Crow Arch Lane, Ringwood, Hampshire, BH24 1NZ, UK  
+44 (0) 1425 478961, sales@doughty-engineering.co.uk - www.doughty-engineering.co.uk





Product Data Sheet

# Super Lightweight Beamer Clamp



A super lightweight half coupler fitted with a 16mm (0.63") Lighting Pin.	
<b>Part Nos</b>	T58125 - Polished T5812501 - Powder Painted Satin Black
<b>Tube Diameter</b>	Ø48 - 51mm (1.89" - 2.01")
<b>Materials</b>	Main Body - AW6082 T6 Aluminium Roll Pins - Stainless Steel Eyebolt - Grade 8.8
<b>Max Tightening Torque</b>	Hand-tight Only
<b>Fixings</b>	Fitted with a 16mm (0.63") Lighting Pin
<b>WLL</b>	100Kg
<b>Weight</b>	0.19Kg (0.42 lbs)
<b>Factor of Safety</b>	5:1
<b>Approval</b>	TÜV Approved

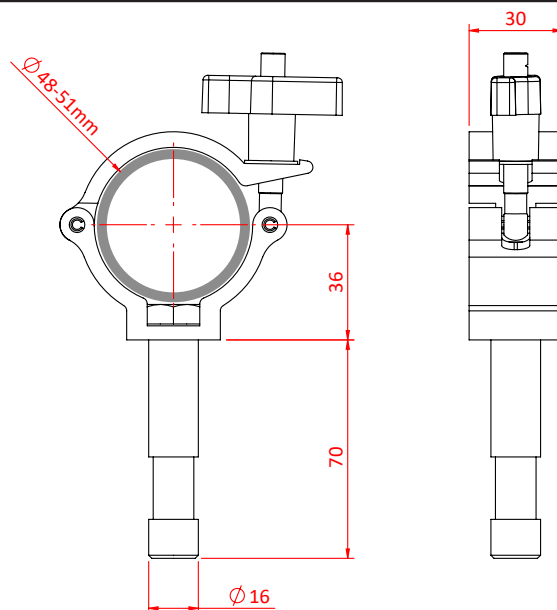

Dimensions in mm

Doughty Engineering Ltd - Crow Arch Lane, Ringwood, Hampshire, BH24 1NZ, UK  
+44 (0) 1425 478961, sales@doughty-engineering.co.uk - www.doughty-engineering.co.uk



Product Data Sheet

# Super Lightweight Panel Clamp



A Super Lightweight Panel Clamp.	
<b>Part Nos</b>	T58130 - Silver T5813001 - Black
<b>Tube Diameter</b>	Ø48 - 51mm (1.89" - 2.01")
<b>Materials</b>	Main Body - AW6082 T6 Aluminium Roll Pins - Stainless Steel Eyebolt Assy - Grade 8.8
<b>Max Tightening</b>	Hand Tight
<b>WLL</b>	Not Rated
<b>Weight</b>	0.16Kg (0.36 lbs)
<b>Approval</b>	TÜV Approved

Dimensions in mm

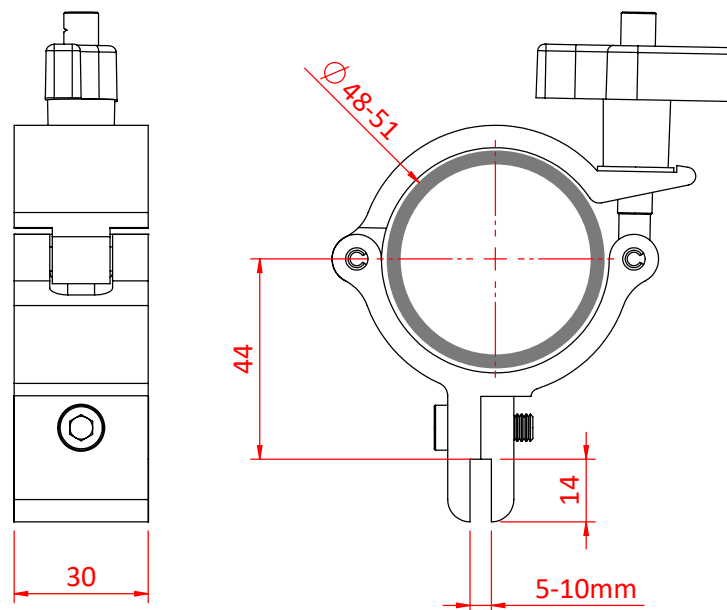

Doughty Engineering Ltd - Crow Arch Lane, Ringwood, Hampshire, BH24 1NZ, UK  
+44 (0) 1425 478961, sales@doughty-engineering.co.uk - www.doughty-engineering.co.uk



Product Data Sheet

# Super Lightweight to Atom Coupler

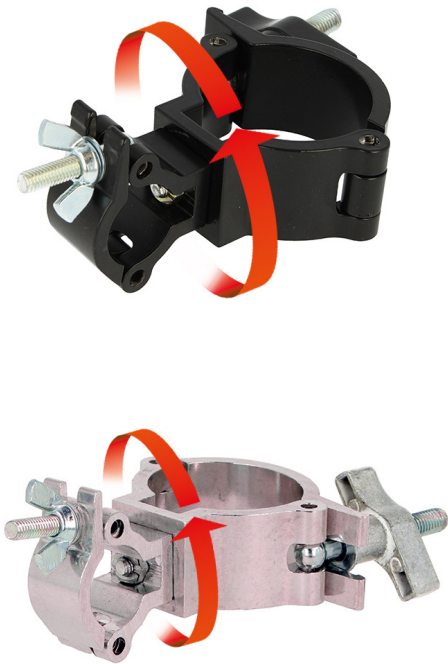

A super lightweight half coupler and 25mm (0.98") atom coupler	
<b>Part Nos</b>	T58132 - Polished T5813201 - Powder Painted Satin Black
<b>Tube Diameter</b>	Ø48 - 51mm (1.89" - 2.01") & Ø25mm (0.98")
<b>Materials</b>	Main Body - AW6082 T6 Aluminium Roll Pins - Stainless Steel Eyebolt - Grade 8.8
<b>Max Tightening Torque</b>	Hand-tight Only
<b>Fixings</b>	N/A
<b>WLL</b>	100Kg
<b>Weight</b>	0.24Kg (0.54 lbs)
<b>Factor of Safety</b>	5:1
<b>Approval</b>	TÜV Approved

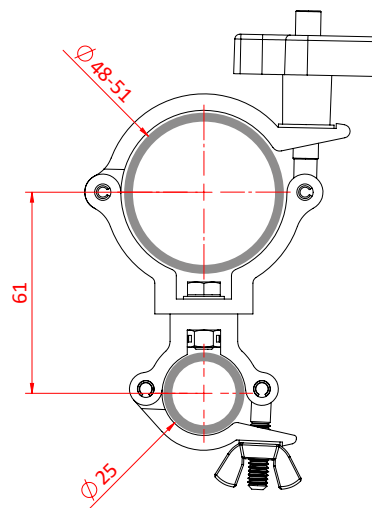
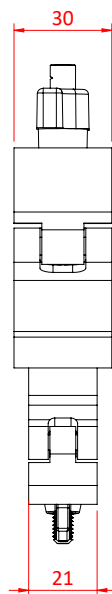

Dimensions in mm

Doughty Engineering Ltd - Crow Arch Lane, Ringwood, Hampshire, BH24 1NZ, UK  
+44 (0) 1425 478961, sales@doughty-engineering.co.uk - www.doughty-engineering.co.uk



Product Data Sheet

# Super Lightweight to Atom Coupler

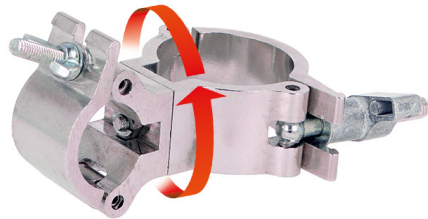

A super lightweight half coupler and 32mm (1.26") atom coupler	
<b>Part Nos</b>	T58133 - Polished T5813301 - Powder Painted Satin Black
<b>Tube Diameter</b>	Ø48 - 51mm (1.89" - 2.01") & Ø32mm (1.26")
<b>Materials</b>	Main Body - AW6082 T6 Aluminium Roll Pins - Stainless Steel Eyebolt - Grade 8.8
<b>Max Tightening Torque</b>	Hand-tight Only
<b>Fixings</b>	N/A
<b>WLL</b>	100Kg
<b>Weight</b>	0.29Kg (0.64 lbs)
<b>Factor of Safety</b>	5:1
<b>Approval</b>	TÜV Approved

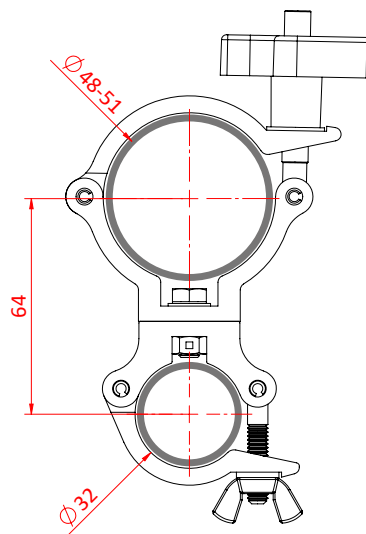
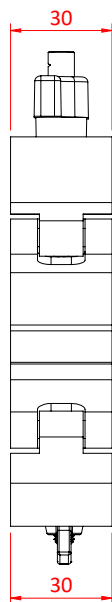

Dimensions in mm

Doughty Engineering Ltd - Crow Arch Lane, Ringwood, Hampshire, BH24 1NZ, UK  
+44 (0) 1425 478961, sales@doughty-engineering.co.uk - www.doughty-engineering.co.uk



Product Data Sheet

# Super Lightweight to Atom Coupler

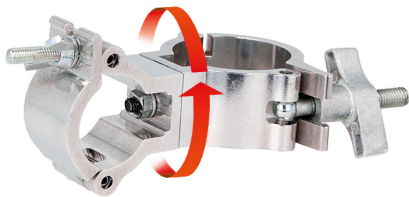
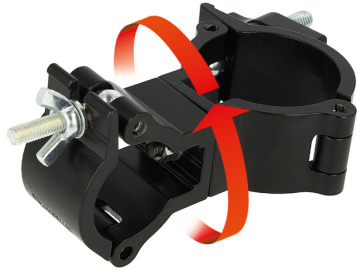

A super lightweight half coupler and 35mm (1.38") atom coupler	
<b>Part Nos</b>	T58134 - Polished T5813401 - Powder Painted Satin Black
<b>Tube Diameter</b>	Ø48 - 51mm (1.89" - 2.01") & Ø35mm (1.38")
<b>Materials</b>	Main Body - AW6082 T6 Aluminium Roll Pins - Stainless Steel Eyebolt - Grade 8.8
<b>Max Tightening Torque</b>	Hand-tight Only
<b>Fixings</b>	N/A
<b>WLL</b>	100Kg
<b>Weight</b>	0.29Kg (0.64 lbs)
<b>Factor of Safety</b>	5:1
<b>Approval</b>	TÜV Approved

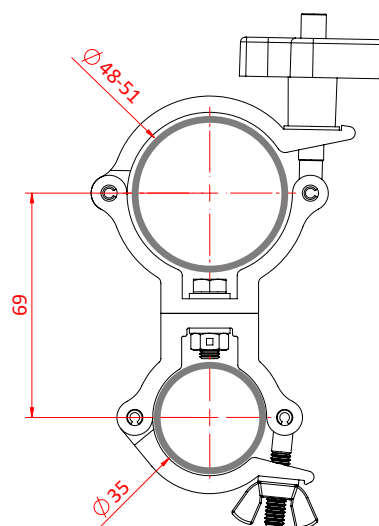
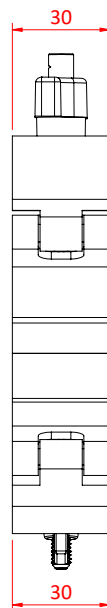

Dimensions in mm

Doughty Engineering Ltd - Crow Arch Lane, Ringwood, Hampshire, BH24 1NZ, UK  
+44 (0) 1425 478961, sales@doughty-engineering.co.uk - www.doughty-engineering.co.uk



Product Data Sheet

# Super Lightweight to Atom Coupler

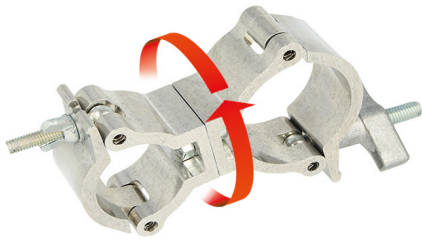

A super lightweight half coupler and 38mm (1.50") atom coupler	
<b>Part Nos</b>	T58135 - Polished T5813501 - Powder Painted Satin Black
<b>Tube Diameter</b>	Ø48 - 51mm (1.89" - 2.01") & Ø38mm (1.50")
<b>Materials</b>	Main Body - AW6082 T6 Aluminium Roll Pins - Stainless Steel Eyebolt - Grade 8.8
<b>Max Tightening Torque</b>	Hand-tight Only
<b>Fixings</b>	N/A
<b>WLL</b>	100Kg
<b>Weight</b>	0.29Kg (0.64 lbs)
<b>Factor of Safety</b>	5:1
<b>Approval</b>	TÜV Approved

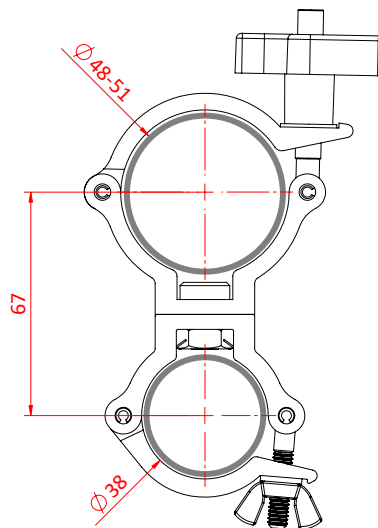
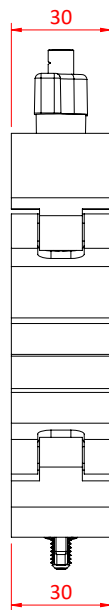

Dimensions in mm

Doughty Engineering Ltd - Crow Arch Lane, Ringwood, Hampshire, BH24 1NZ, UK  
+44 (0) 1425 478961, sales@doughty-engineering.co.uk - www.doughty-engineering.co.uk

# Inspection List

ITEM	FAULT	REPAIR	DATE	SIGNATURE



## EC-DECLARATION OF CONFORMITY

According to the Machinery Directive 2006/42/EEC Annex II

### Doughty Engineering Ltd

Crow Arch Lane  
Ringwood  
Hampshire  
BH24 1NZ

Herewith declares that:

**T58122, T5812201, T58123, T5812301, T58124, T5812401, T58125, T5812501,  
T58130, T5813001, T58132, T5812301, T58133, T5813301, T58134, T5813401,  
T58135 & T5813501**

### Super Lightweight Clamp Range

Are in compliance with the following harmonized standards/standards/regulations.

#### Machinery Directive 2006/42/EEC annex II

- Machinery Directive 2006/42/EC;
- BS EN 12100:2010 – Safety of Machinery – General Principles for Design – Risk Assessment and Risk Reduction.
- BS 7906-1:2005 - Lifting Equipment for Performance, Broadcast and Similar Applications;
- DGUV 17 – Regulations for Stages and Studios
- DGUV Information 215-313

Signed for and behalf of **Doughty Engineering Ltd**

Name **Dan Phillips**

A handwritten signature in black ink, appearing to be "DP", written over the printed name "Dan Phillips".

Position **Company Director** being the person responsible appointed by the manufacturer.

Company Registration No. London 972614  
Registered Office: Crow Arch Lane, Ringwood, Hants, BH24 1NZ  
Directors: J.C.G. Chiverton. S.C. Wright. D. Phillips. D.M. Chorley





**Doughty Engineering**

Crow Arch Lane

Ringwood

Hampshire

BH24 1NZ

Telephone: +44 (0) 1425 478961

Email: [sales@doughty-engineering.co.uk](mailto:sales@doughty-engineering.co.uk)

Website: [www.doughty-engineering.co.uk](http://www.doughty-engineering.co.uk)

**Note:** Whilst every effort has been made to ensure that the information contained within this manual is correct, Doughty Engineering does not accept any liability for errors or omissions. Specifications and technical data are intended for guidance purposes only and may vary.