

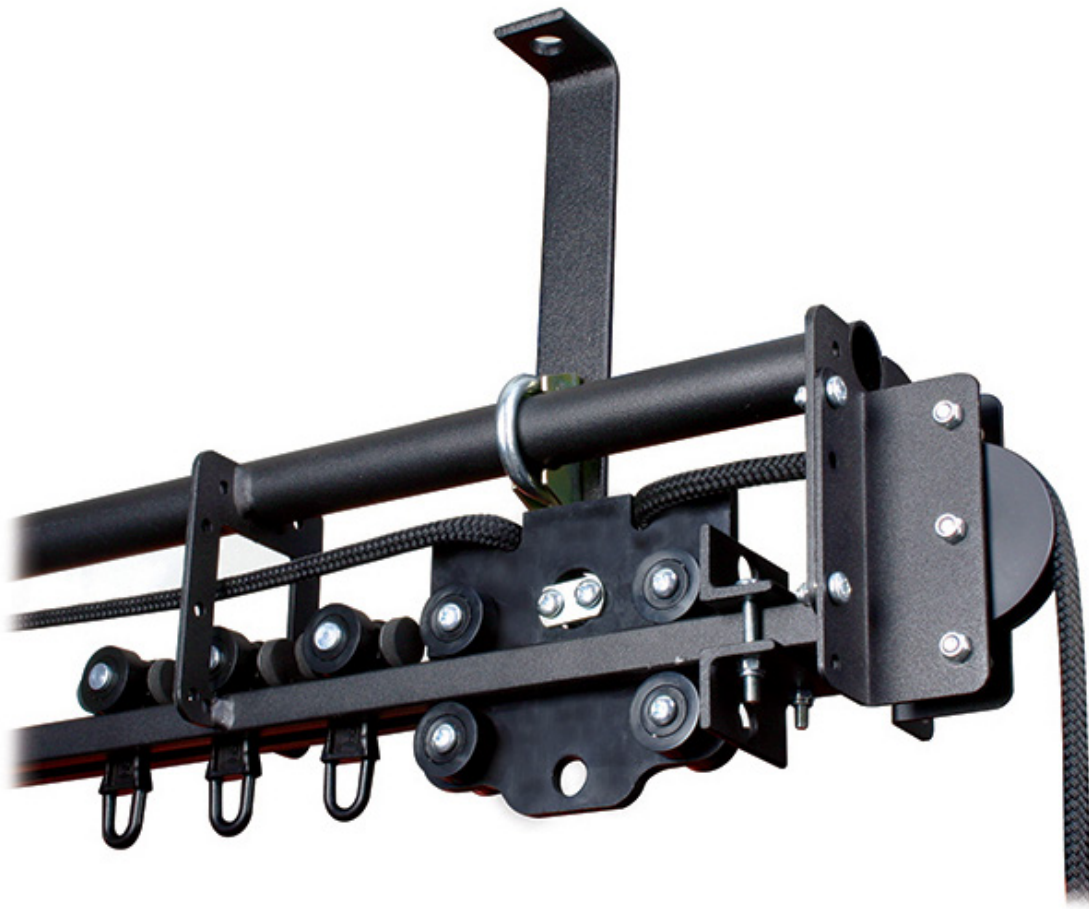

USER MANUAL

# Six Track



**Original Instructions**

**Six Track Range:**

**T63705 - T63952**

Six Track is a modular curtain track system suitable for a wide range of stage and studio applications. Six Track kits include all the components required to install your chosen track length. A typical kit comprises track, end stops, ball raced runners, adjustable support brackets and a fixing kit.

Line operated track kits also include a master runner, pulleys, hauling line, line supports, and a weighted hand pulley. In addition, line operated track kits with overlap include a second master runner, overlap brackets and overlap pulleys.

The Six Track Variable Speed Track Drive is a single-phase rail mounted drive system. The wall mounted control box enables a variable speed drive system. An optional open/close remote-control unit is also available.

Six Track is strictly for professional use. Only competent persons are permitted to install and use Six Track. A competent person in this respect is an individual with relevant technical education, training and/or experience enabling him or her to perceive risks and to avoid hazards occurring during use of a product.

Doughty has endeavoured to deliver the highest degree of accuracy possible. However, continuous improvement of our products is a Doughty Policy. Therefore, product specifications are subject to change without notice. Readers and users are encouraged to notify Doughty of errors and send in suggestions for improvement. All communications will be carefully considered for future printings of this manual and changes to our products.

## Six Track Range

Six Track is a curtain track system made up from a variety of interchangeable parts to form a flexible, efficient system. Six Track can be configured as:

**Walk-along System** - This is a system where a person opens/closes the curtains/drapes manually by pulling the curtain. This system can be straight or curved being a single swipe or a system with an overlap.

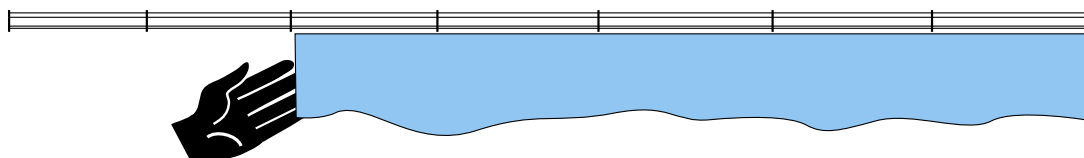

**Manual Line Operated System** - This system is operated with an 8mm polyester hauling line. The hauling line can be operated by hand, or with a wall or floor mounted Manual Track Drive. This system can be straight or curved being a single swipe or a system with an overlap.

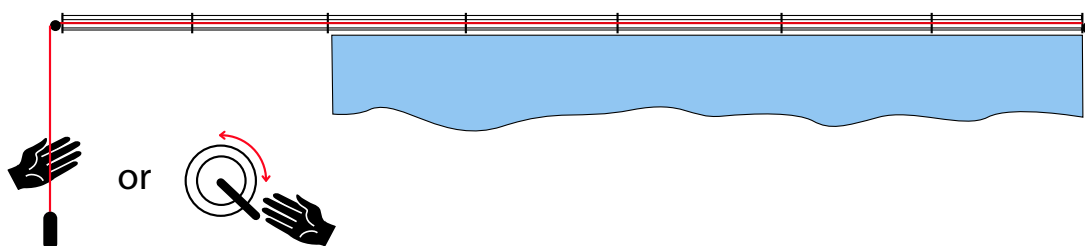

**Motorised System** - This system is operated with an 8mm hauling line. The hauling line is operated by an Electric Track Drive in conjunction with limit switches to set the travel. This system can be straight or curved being a single swipe or a system with an overlap.

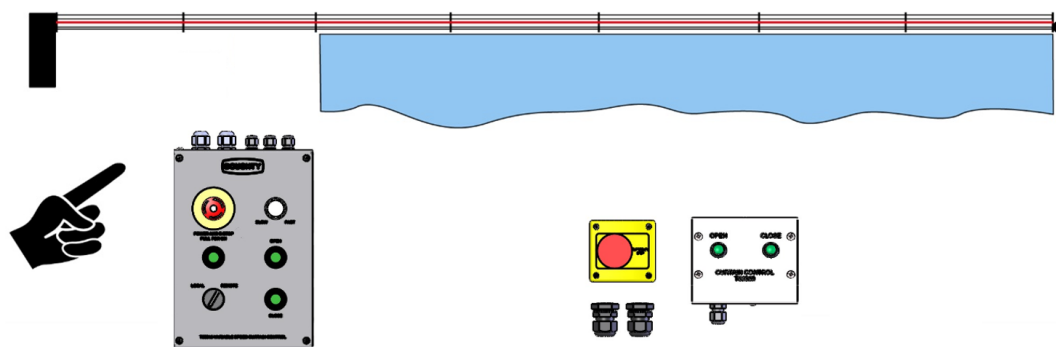

The Variable Speed Track Drive is mounted at one end of the rail and has a wall mounted control box. An optional open/close remote-control unit is also available.

- Six Track can be operated in 15° Celsius up to +60° Celsius.
- Six Track is for indoor use only.
- The use of Six Track is the sole responsibility of the user.
- To use Six Track the user must observe the instructions to be found in this manual.
- All persons who use Six Track must be acquainted with this manual and must be informed about its potential hazards.
- It is also imperative to observe the local accident prevention regulations and/or occupational health and safety regulations.
- The manufacturer is not liable for indirect consequential damage and financial loss. The manufacturer shall not be liable for any changes made to the device nor for any damage resulting from such changes.

### **MODIFICATION**

Six Track components should not be modified in any way. If there is a requirement for non-standard Six Track parts for a special purpose please contact your Doughty agent.



### Warning

- DO NOT exceed any working load limit indicated.
- Six Track shall be inspected by a competent person as often as required but with a minimum of once a year and maintain written records.
- Six Track must be taken out of service immediately if, during use, repair or maintenance any serious damage is discovered.
- Repairs can be undertaken only by authorised (Doughty trained) personnel. If any doubt contact the manufacturer.

### TRANSPORT AND STORAGE:

- Before Six Track Systems are put into storage they must be checked for defects. Defective Six Track components must be clearly marked and put aside so they cannot be re-used.
- Ensure the product is stored and kept in a dry, ventilated place to avoid corrosion.

## Installation & Operation

- Installation should only be carried out by a competent person familiar with this type of equipment.
- All suspension points must be assessed to ensure they are adequate to suspend the load.
- A typical Six Track will be installed at a height such that any failure could be hazardous.
- Before starting the installation, the load for each support should be calculated allowing for the weight of all the track and accessories as well as the curtain whether open or bunched or part bunched as during opening. Care must be taken to allow for loads imposed during operation, the load on a twin head pulley may be increased by up to 50kg because of the hauling line.
- The maximum recommended length of a single span track is 10.0 metres and 18.0 metres for an overlap track system.
- The maximum distance between track supports is approximately 2.25m for open cloth and approximately 1.60m for bunched cloth.
- The maximum load per runner is 6kg and has a recommended spacing of 300mm when the cloth is open. Swivel hooks are best used on the curtains instead of eyelets or ties.

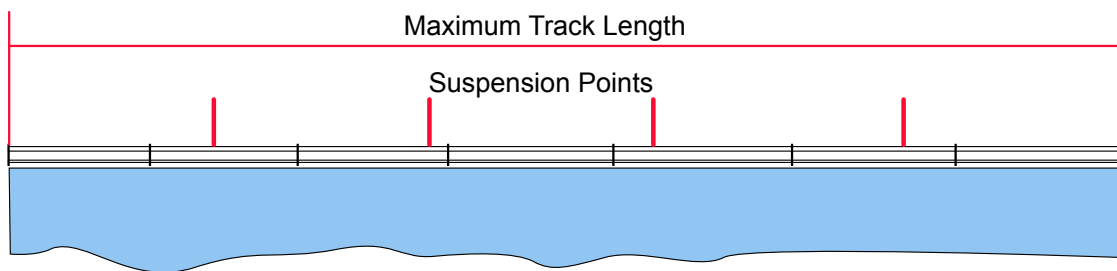

A Typical Swivel Hook

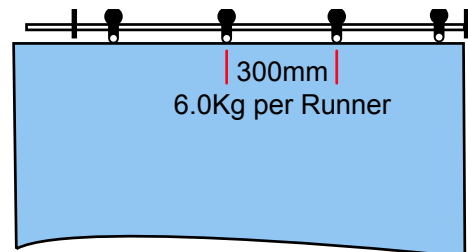

## Six Track Straight Sections

Straight sections are available in the following lengths:

- T63705** - 0.25m Straight
- T63706** - 0.50m Straight
- T63707** - 0.75m Straight
- T63708** - 1.00m Straight
- T63710** - 2.00m Straight
- T63715** - 3.00m Straight

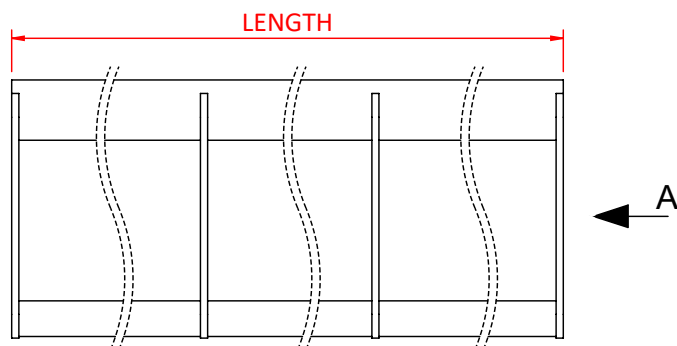

Custom lengths can be made to order.

Dimensions in mm

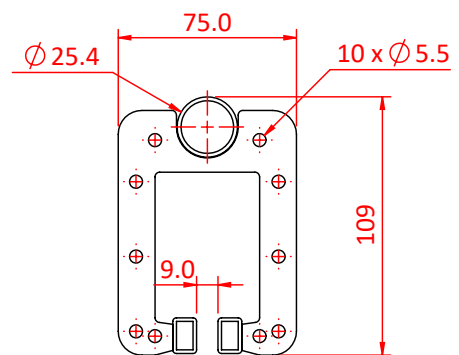

VIEW ON ARROW "A"

Each Six Track Straight section is supplied with a **T63748** Spigot Plate to aid alignment.

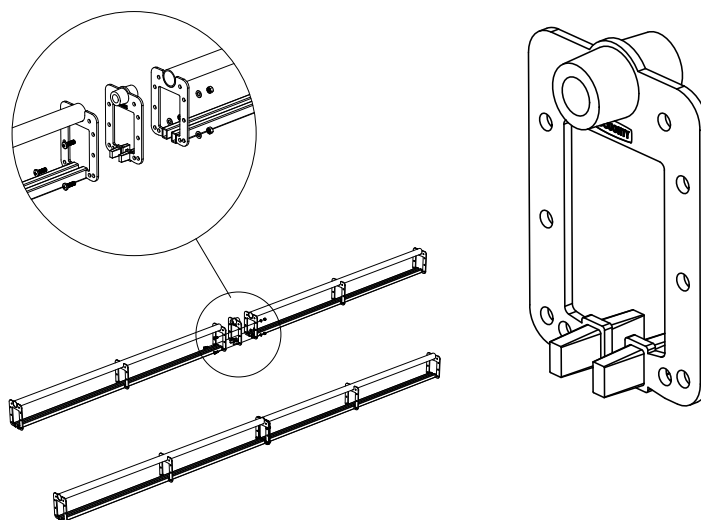

### T63795 - Fixing Kit

The Six Track fixing kit consists of: 100 x M5 x 16 screws, 100 x M5 Washers and 100 x M5 Nuts.

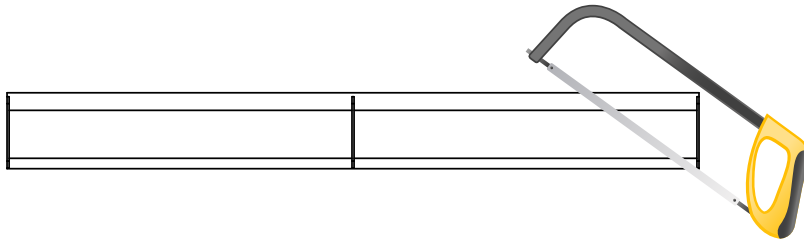

Six Track can be cut on site & fitted with an Adaptor Plate or End Plate. A minimum of four fixings are required per joint.

### T63765 - Bolt On End Plate

The Bolt On End Plate is used to terminate a cut section of Six Track.

Two 5mm diameter holes are required to be drilled.

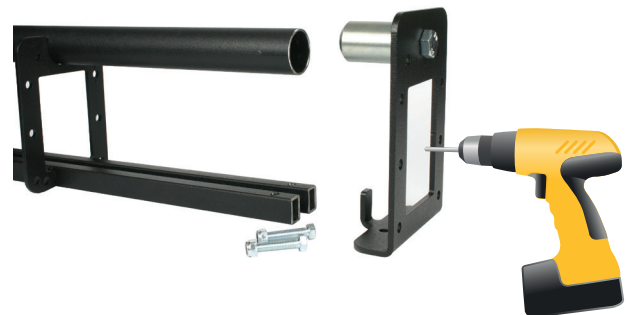

### T63766 - Adaptor Plate

The Adaptor Plate is used on track sections which have been cut to be used mid track and require the runner to pass through.





## Six Track Curved Sections

The following curved sections are available:

T63730 - 0.50m x 90°

T63733 - 0.60m x 90°

T63731 - 0.75m x 90°

T63734 - 0.90m x 90°

T63732 - 1.00m x 90°

T63738 - 2.00m x 90°

T63739 - 3.00m x 90°

T63735 - 0.50m x 45°

T63736 - 0.75m x 45°

T63737 - 1.00m x 45°

Custom curves can be made to order.

Dimensions in mm

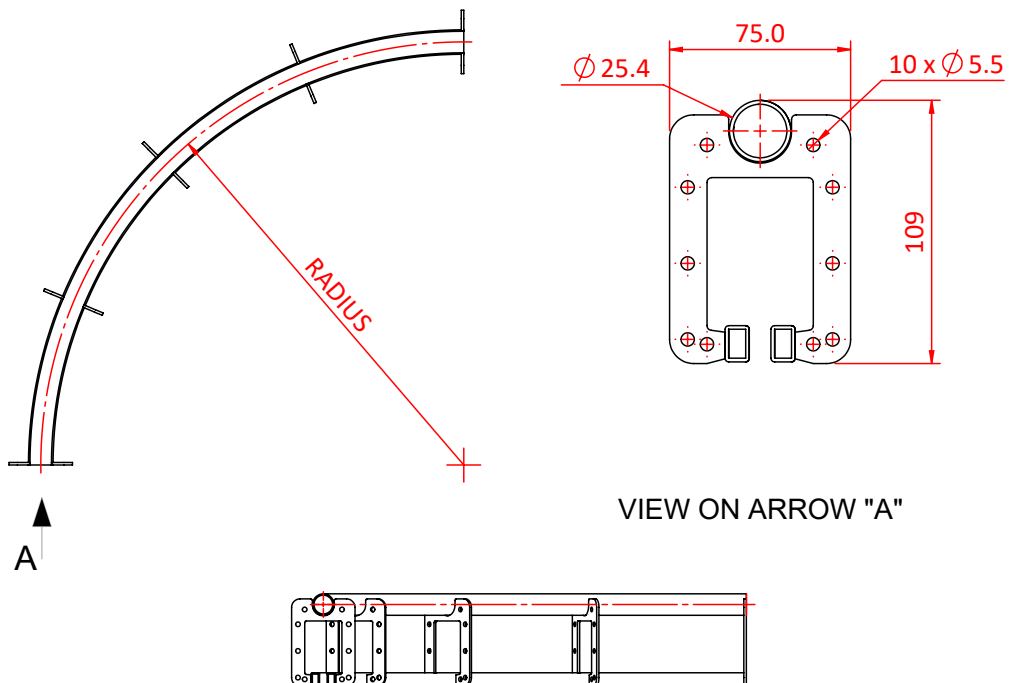

## Six Track Runners

Six Track Runners have a WLL of 6Kg and are recommended to be used at 300mm intervals.

**T63756** - Ball Raced Runner

**T63757** - Plain Runner

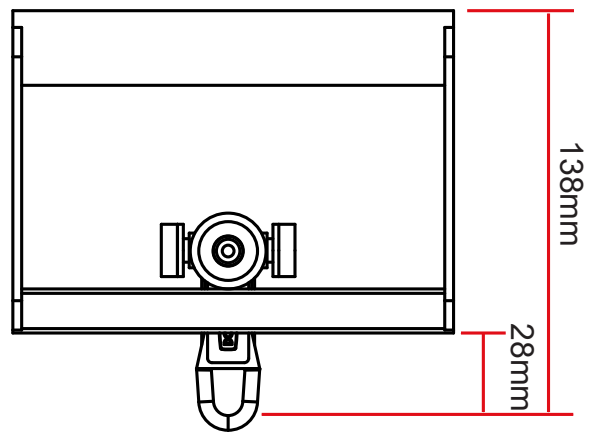

## **T63755** - Master Runner

A Master Runner is used to lead the curtain on every system, Walk-along, Line operated and Electric track drive.

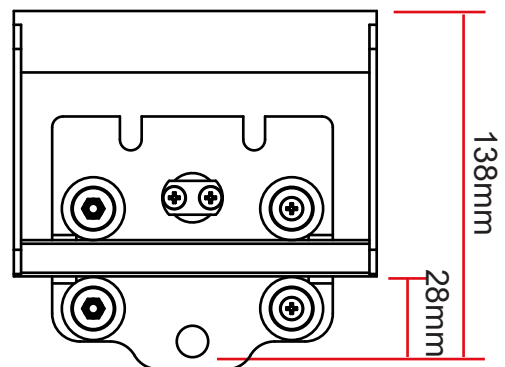

## **T63796** - Nylon Twin Hooks

Nylon Twin Hooks are used to connect curtains to Six Track Runners



Six Track is suspended by attaching clamps/brackets to the  $\text{\O}25\text{mm}$  top tube of the rail sections. There are a variety of brackets available to cover most install situations. Care must be taken to ensure all suspension points are adequate to suspend the load.

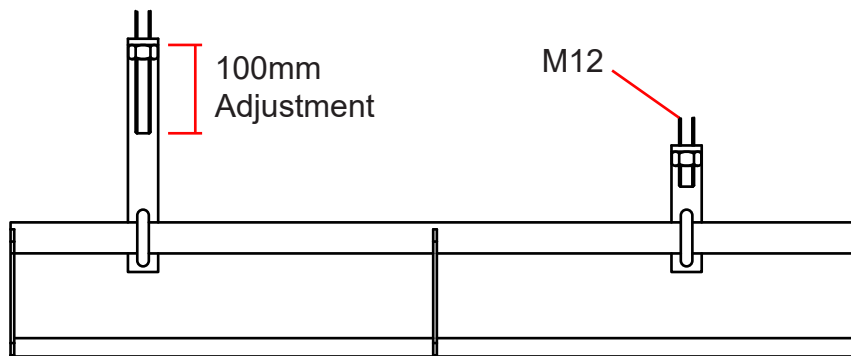

### Support Brackets

Mild steel brackets are designed to suspend Six Track from its top rail using M12 Studding. Maximum span between supports with an open cloth is 2.25m. Maximum span between end supports with a bunched cloth is 1.60m. We recommend fixings every 1.5M if possible.

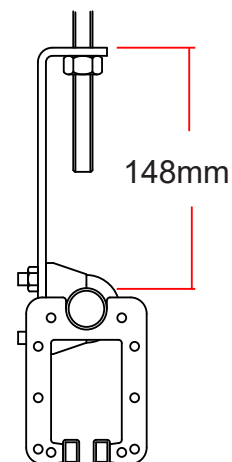

**T63750** - Adjustable Support Bracket  
**T63751** - Short Support Bracket

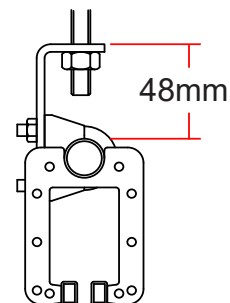

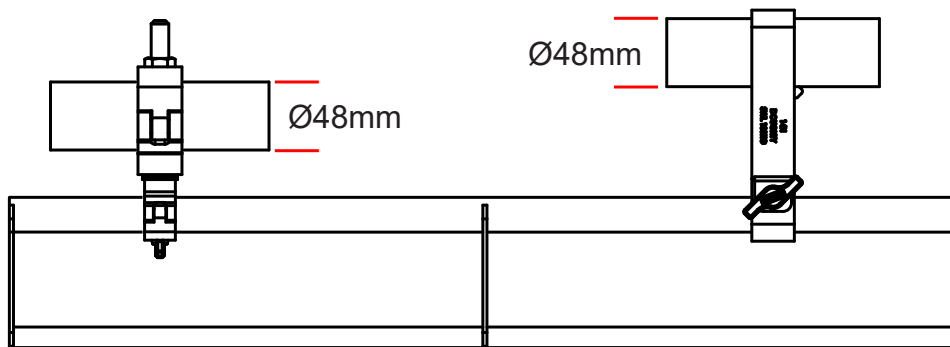

## T63785 - Swing Arm Boom

Consists of a pair of high tensile extruded aluminium clamps back to back designed to swivel. Suitable for 48mm to 51mm diameter tubes one end and 25mm tubes the other. Specifically designed to allow single track lengths to be mounted to trussing, scaffold tubes and lighting bars.

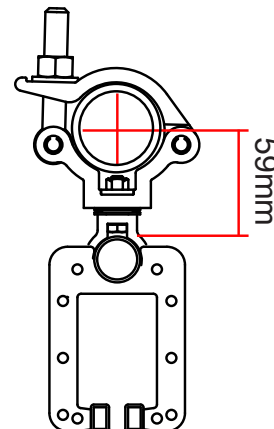

## T63753 - Barrel Bracket

A mild steel bracket specially designed to enable you to hang overlap tracks from a standard 48mm diameter barrel. Each clamp is fitted with a protection plate to prevent damage to the top tube of the track.

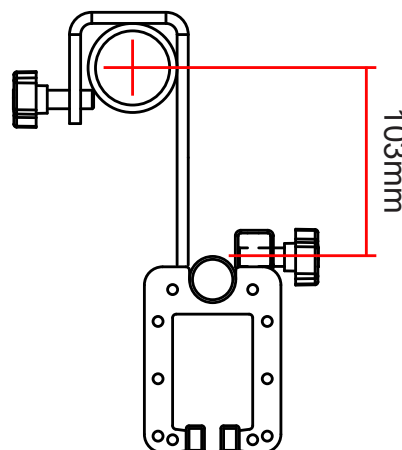

Twin Tracks and Overlaps are spaced apart with purpose made brackets.

### T63752 - Overlap Bracket

A mild steel bracket designed to create an overlap with the Six Track system. Two Overlap Brackets are required and the recommended length of overlap is 1M.

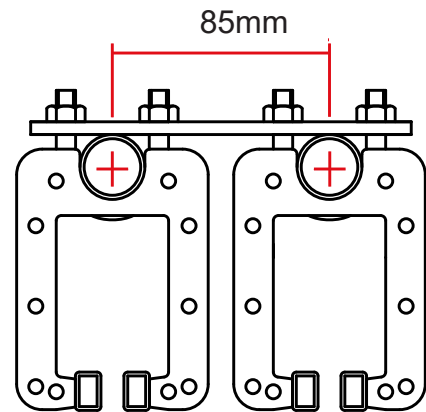

### T63754 - Parallel Bracket

A mild steel bracket designed to hold two Six Track straight sections parallel to each other at 150mm centres to create twin tracks.

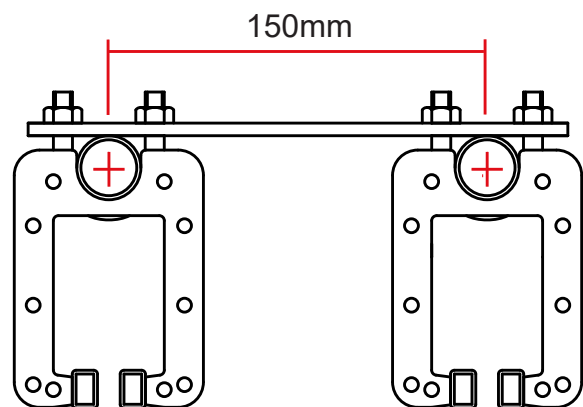

### Walk-along Systems - Single Swipe

Six Track Walk-along Systems are basic curtain tracks which are operated by moving the curtains by hand. Listed below are the list of components required to make a system.

Checklist:

1. Track Sections
2. Suspension Brackets
3. Master Runner
4. Curtain Runners
5. End Stops
6. Fixing Kit (for joining Track Sections)

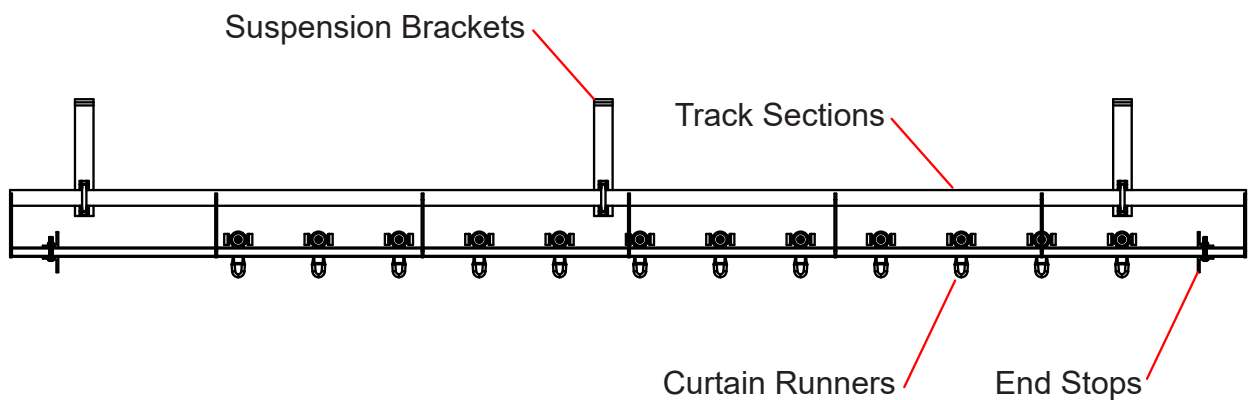

### Walk-along Track Kits

The following track kit include all the components to make a straight walk-along system. Each kit includes the recommended quantity of T63750 Adjustable Support Brackets. Contact [sales@doughty-engineering.co.uk](mailto:sales@doughty-engineering.co.uk) for a full component list.

**T63941** - 4.0m Straight Kit

**T63942** - 5.0m Straight Kit

**T63943** - 6.0m Straight Kit

**T63944** - 7.0m Straight Kit

**T63945** - 8.0m Straight Kit

**T63946** - 9.0m Straight Kit

**T63947** - 10.0m Straight Kit

**T63948** - 11.0m Straight Kit

**T63949** - 12.0m Straight Kit

**T63950** - 13.0m Straight Kit

**T63951** - 14.0m Straight Kit

**T63952** - 15.0m Straight Kit

## Line Operated Systems - Single Swipe

Six Track Line Operated Systems are curtain tracks which use a hauling line that is operated by hand with a weighted or floor mounted pulley. It can also be operated with a manual track drive which can either be floor or wall mounted. Listed below are a list of components required to make a system.

Checklist:

1. Track Sections
2. Suspension Brackets
3. Master Runner
4. Curtain Runners
5. End Stops
6. Fixing Kit (for joining Track Sections)
7. Twin Head Pulley
8. Return Pulley
9. Weighted pulley, floor mounted pulley, wall mounted track drive or floor mounted track drive
10. Hauling Line
11. Line Supports (if required)
12. Single Guide Pulleys (if required)
13. Twin Guide Pulleys (if required)

Line supports and single guide pulleys are recommended on systems 5.0m and longer.

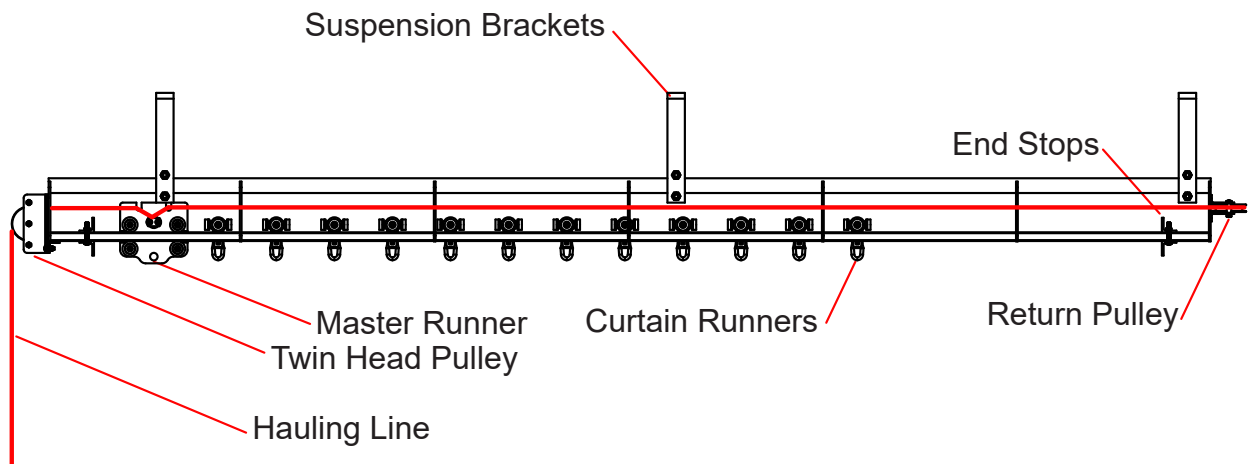

**T63908** - 4.0m Straight Kit  
**T63909** - 5.0m Straight Kit  
**T63910** - 6.0m Straight Kit  
**T63911** - 7.0m Straight Kit  
**T63912** - 8.0m Straight Kit  
**T63913** - 9.0m Straight Kit

**T63914** - 10.0m Straight Kit  
**T63915** - 11.0m Straight Kit  
**T63916** - 12.0m Straight Kit  
**T63917** - 13.0m Straight Kit  
**T63918** - 14.0m Straight Kit  
**T63919** - 15.0m Straight Kit

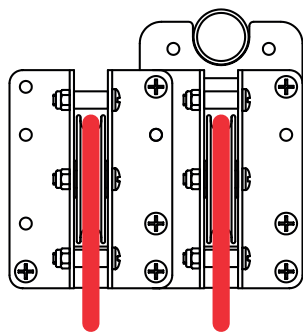
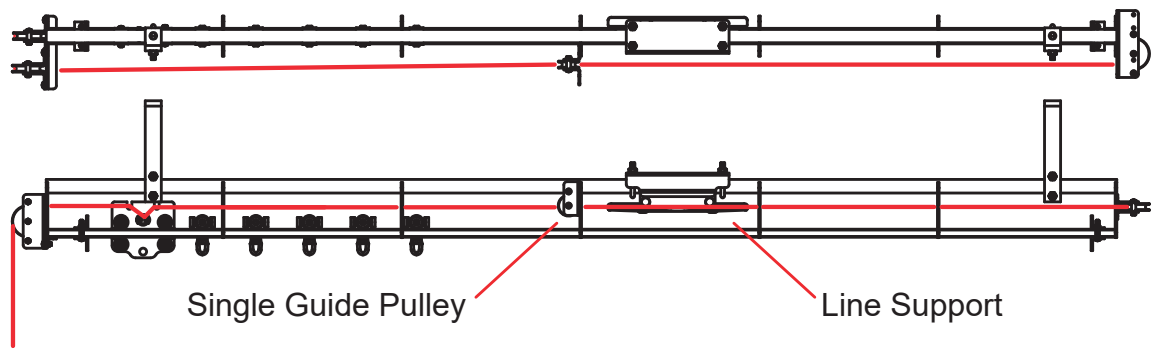

**T63776** - Twin Head Pulley

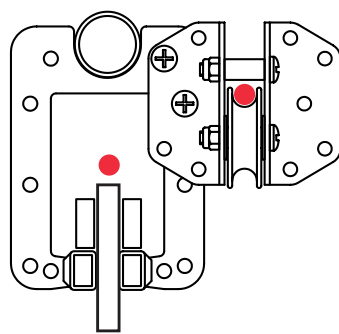

**T63777** - Single Guide Pulley

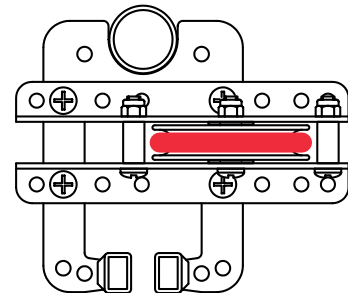

**T63775** - Return Pulley

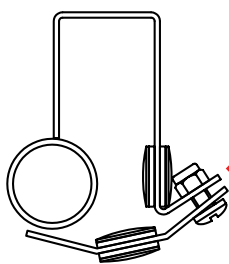

Step 1

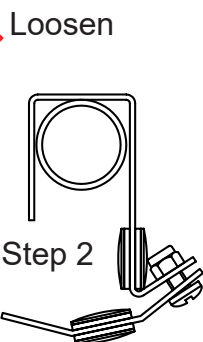

Step 2

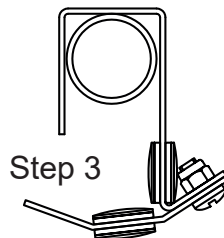

Step 3

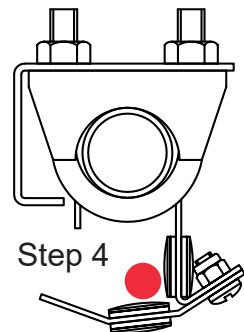

Step 4

Loosen

**T63770** - Line Support



Step 1



Step 2

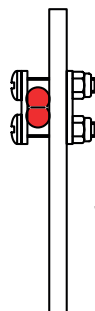

Step 3

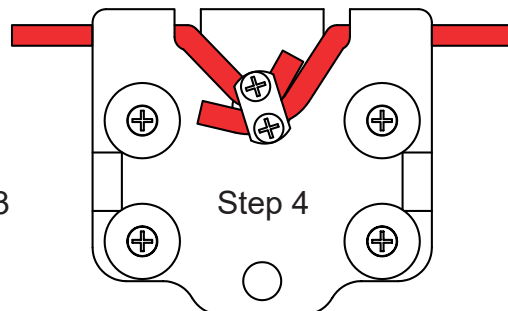

Step 4

**T63775** - Master Runner



## Line Operated Systems - Curves

Six Track line operated curves use double guide pulleys to guide the hauling line.

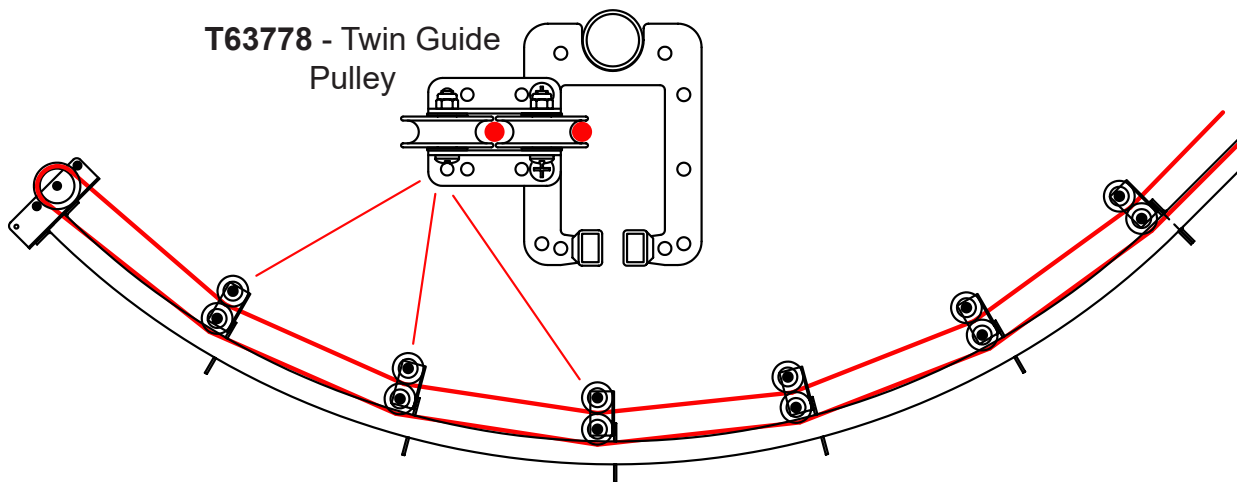

## Line Operated Systems - Crossover

Systems containing two or more curves may require the hauling line to crossover to enable the correct routing. This is achieved by using two T63777 Single Guide Pulleys as below.

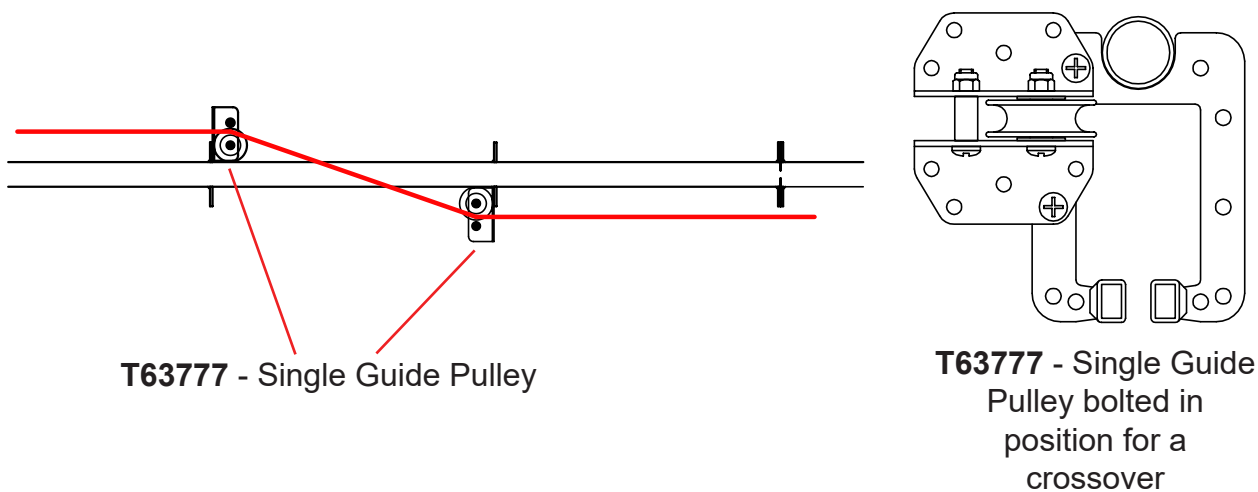

## Line Operated Systems - Overlap

Six Track line operated systems can be installed in an overlap configuration. This configuration requires the use of overlap brackets and twin guide pulleys.

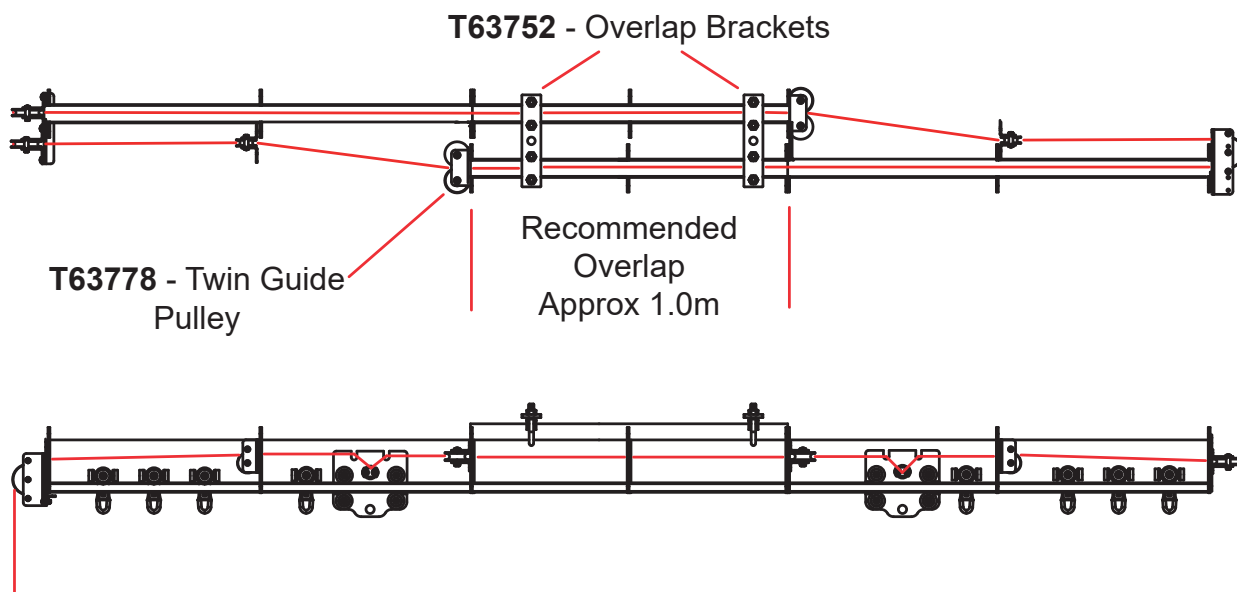

### Typical Single Swipe Layout

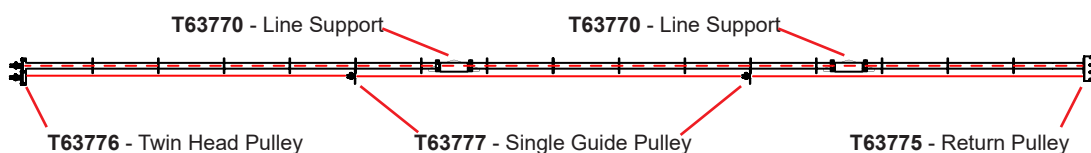

### Typical Overlap Layout

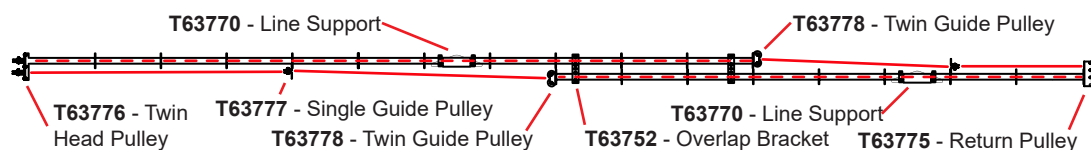

### Typical Overlap Layout with Curves

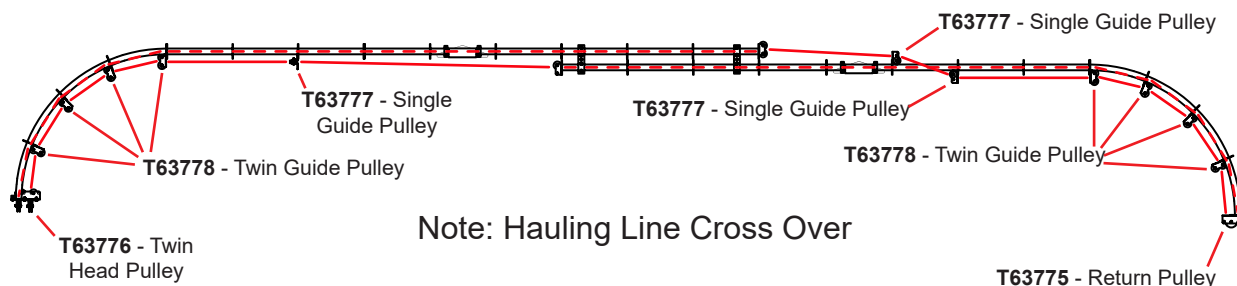

## Line Operated Systems - Hand drives

Six Track line operated systems can be operated either by hauling hand over hand or by turning a crank handle of a manual track drive unit.

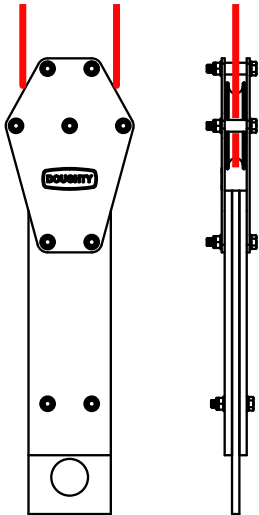

**T63820 -**  
Weighted Handline  
Pulley

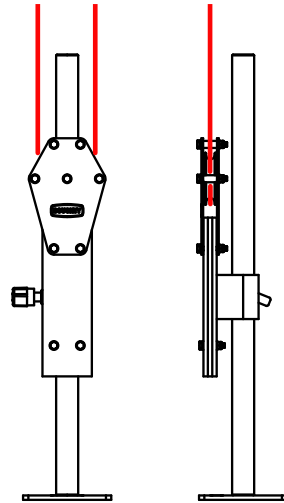

**T63825 -**  
Floor Fixed  
Handline Pulley

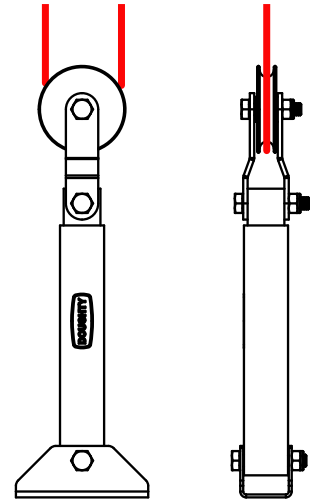

**T63830 -**  
Sprung Floor  
Pulley

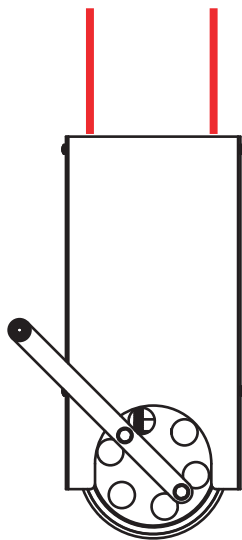

**T63840 -**  
Manual Track Drive  
Wall Mounted

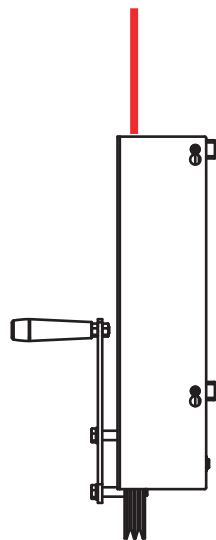

**T63841 -**  
Manual Track Drive  
Fitted with Floor Stand

### Routing the Hauling Line - Manual Drive Tracks

The diagram below shows the route of the hauling line through the guide pulleys and the line tensioner. The tensioner springs must be compressed during the routing of the hauling line and when released should remain partially compressed to compensate for any line stretch. Replace the cover using the six fixings before the drive is operated.

In case of the loss of drive the hauling line will need re-tensioning. The following steps explain how to re-tension the hauling line:

1. Remove the cover by removing the six fixings.
2. Compress the tensioner spring.
3. Loosen the rope clamp on the master runner.
4. Take up the slack line through the master runner.
5. Tighten the rope clamp on the master runner.
6. Release the tensioner spring ensuring it remains partially compressed.
7. Replace the cover.

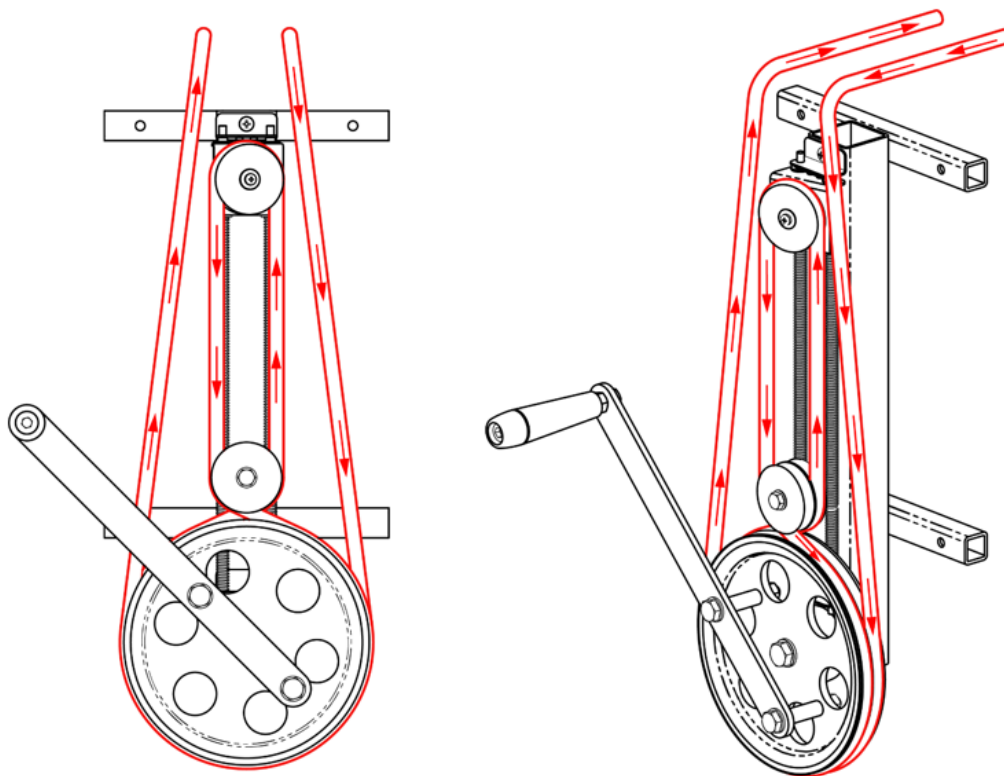

### Variable Speed Curtain Track Drive - T63845

The Variable Speed Electric Track Drive is designed to be mounted on the end of Doughty Six Track rail. The power supply is 230 volts 50hz, single phase and must be fused at 5 amps. The unit is supplied with a mains plug to BS1363 incorporating a 5-amp fuse. Normal track speed is 0.75 metres/second but this may be increased or decreased using the control box supplied. The maximum tractive effort is 20kg

The drive unit can be bolted to the end of the rail in one of two positions as best suits installation. The drive unit is fixed to the rail using 4 off M5 nuts.

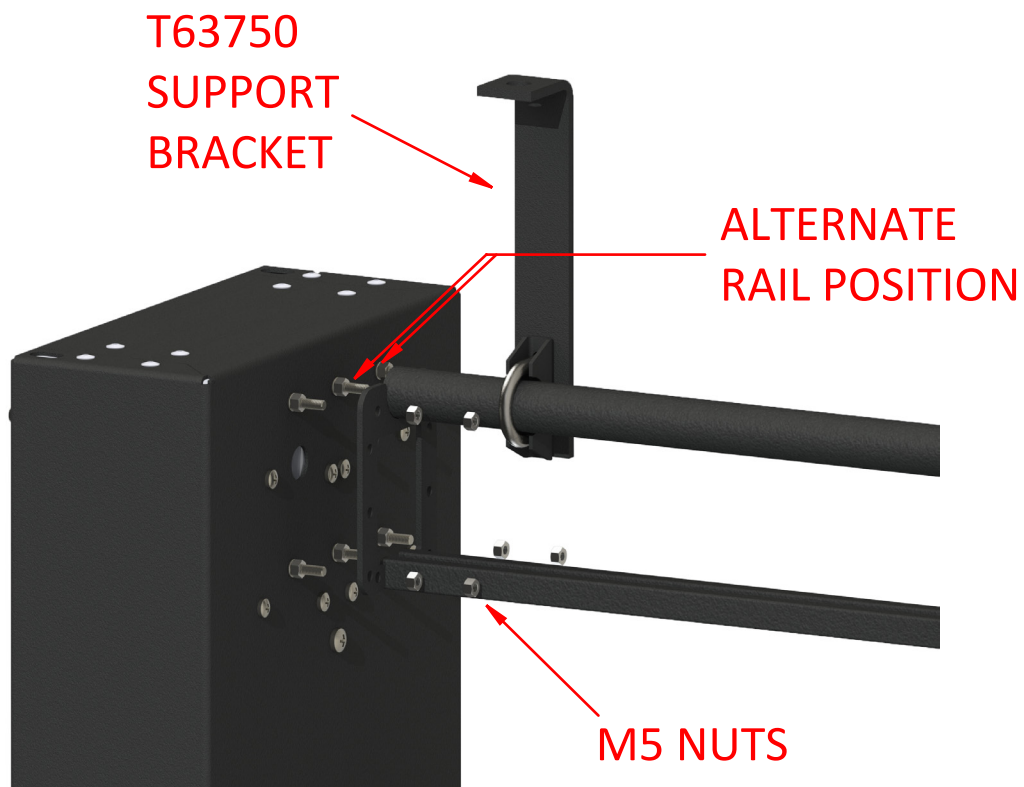

The track should be supported with a suspension bracket within 60mm of the end of the track.

### Routing the Hauling Line - Electric Drive Tracks

The diagram below shows the route of the hauling line through the guide pulleys and the line tensioner. The tensioner springs must be compressed during the routing of the hauling line and when released should remain partially compressed to compensate for any line stretch. Replace the cover using the six fixings before the drive is operated.

In the case of the loss of drive the hauling line will need re-tensioning. The following steps explain how to re-tension the hauling line.

1. **Disconnect the power lead.**
2. Remove the cover by removing the six fixings.
3. Compress the tensioner spring.
4. Loosen the rope clamp on the master runner.
5. Take up the slack line through the master runner.
6. Tighten the rope clamp on the master runner.
7. Release the tensioner spring ensuring it remains partially compressed.
8. Replace the cover.
9. Re-connect the power and test.

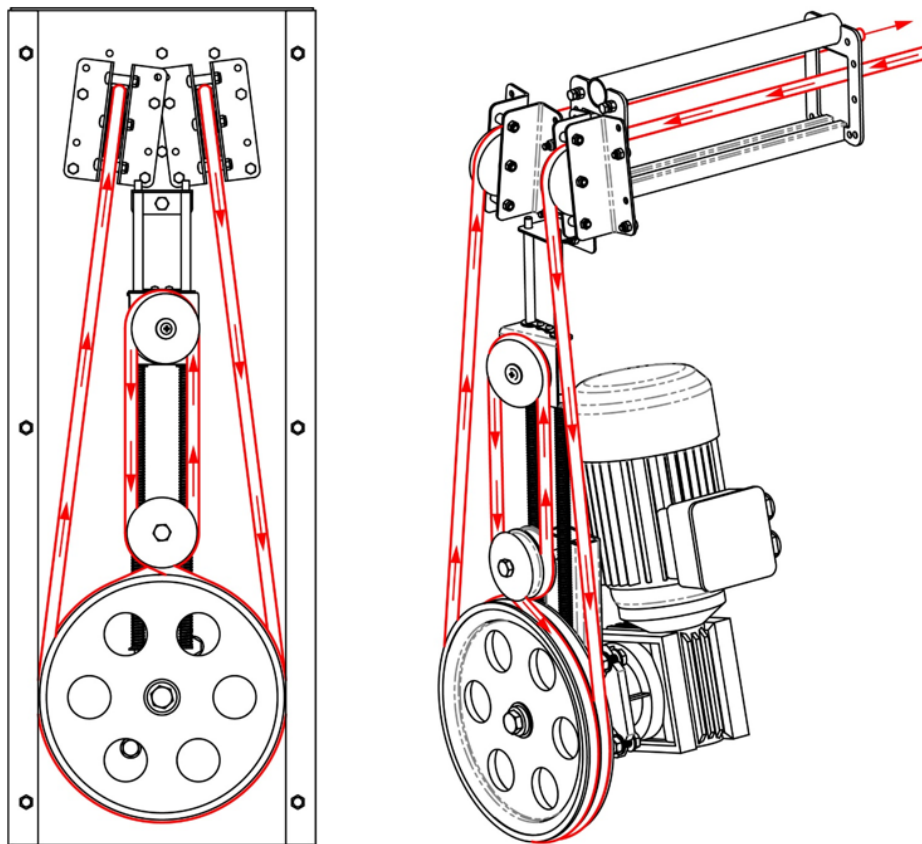

### Electric Track Drive Limit Switches

Motorised track systems must be fitted with two limit switches. The limit switches are activated by the master runner and create the open and closed stopping positions for curtains or scenery. The limit switches are mounted to the top tube of the rail using 2 off rail clamps and 'U' bolts.

Limit switch wires are to be secured to the top tube of the rail using cable ties. Ensure that the limit switch wires are routed so that they cannot come into contact with any moving parts. Limit switches are connected to the drive control box as shown in the circuit diagram (Fig.1 on page 25).

The diagram below shows a typical limit switch installation on the track.

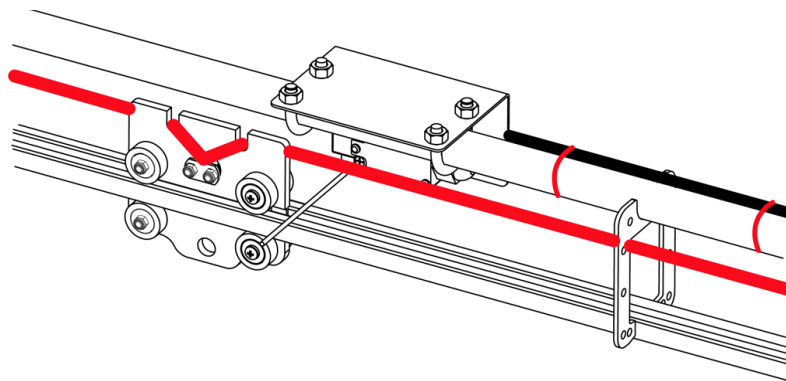

The limit switch arms must clear the rail profiles and so must be positioned on the rail with the 30mm and 125mm clearances shown below. The master runner must also be oriented on the rail with the hauling rope clamp facing in the direction as shown below.

Failing to install the limit switches correctly can damage the track drive.

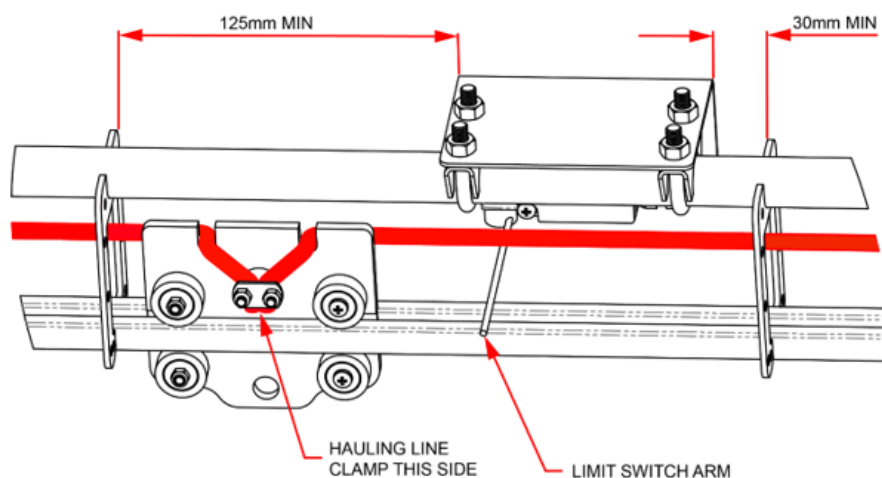

## Load Control

The local control station has an emergency stop button which should be pushed in to isolate the drive except when the drive is in use. Ten metres of screened cable is provided for connection to the motor. Connecting points are provided for the limit switches. Connecting points are provided for the optional remote control. The control functions are as follows:

- Emergency stop which switches the control off completely.
- 'Open' and 'close' buttons.
- Local/remote control selector switch.
- Power on indicator.

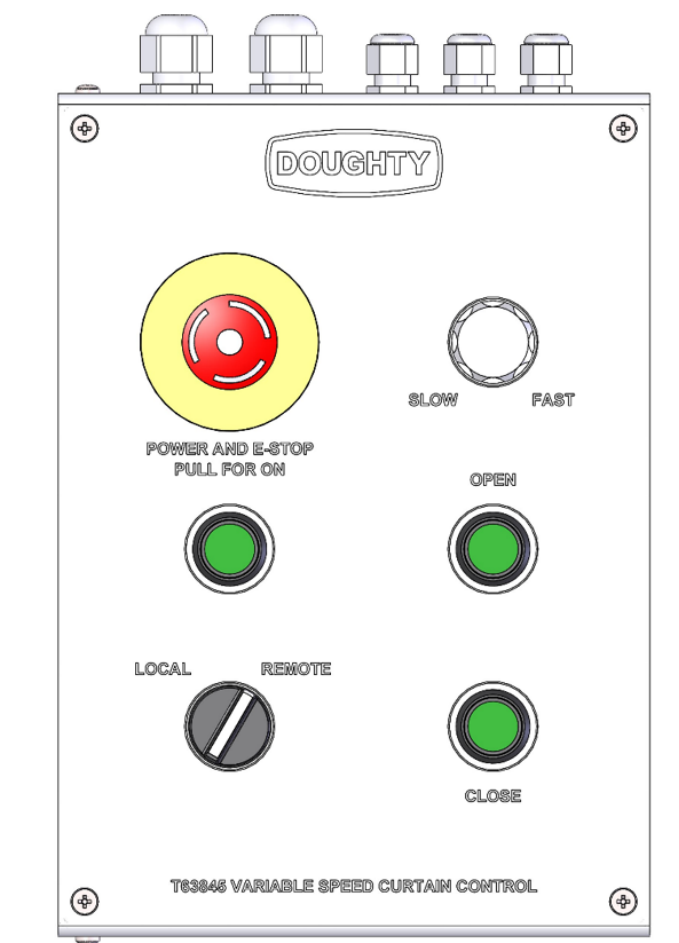



### Optional Remote Control - T63850

The optional remote-control station comprises a control box having 'open' and 'close' buttons for operation of the drive from a remote position. Twenty metres of cable is provided with the remote control.

A remote 'emergency stop' control is provided for mounting near the remote-control box. This control cuts the mains supply to the local control to provide an independent emergency stop. Ten metres of cable is provided with the emergency stop.



Circuit Diagram (Fig. 1)

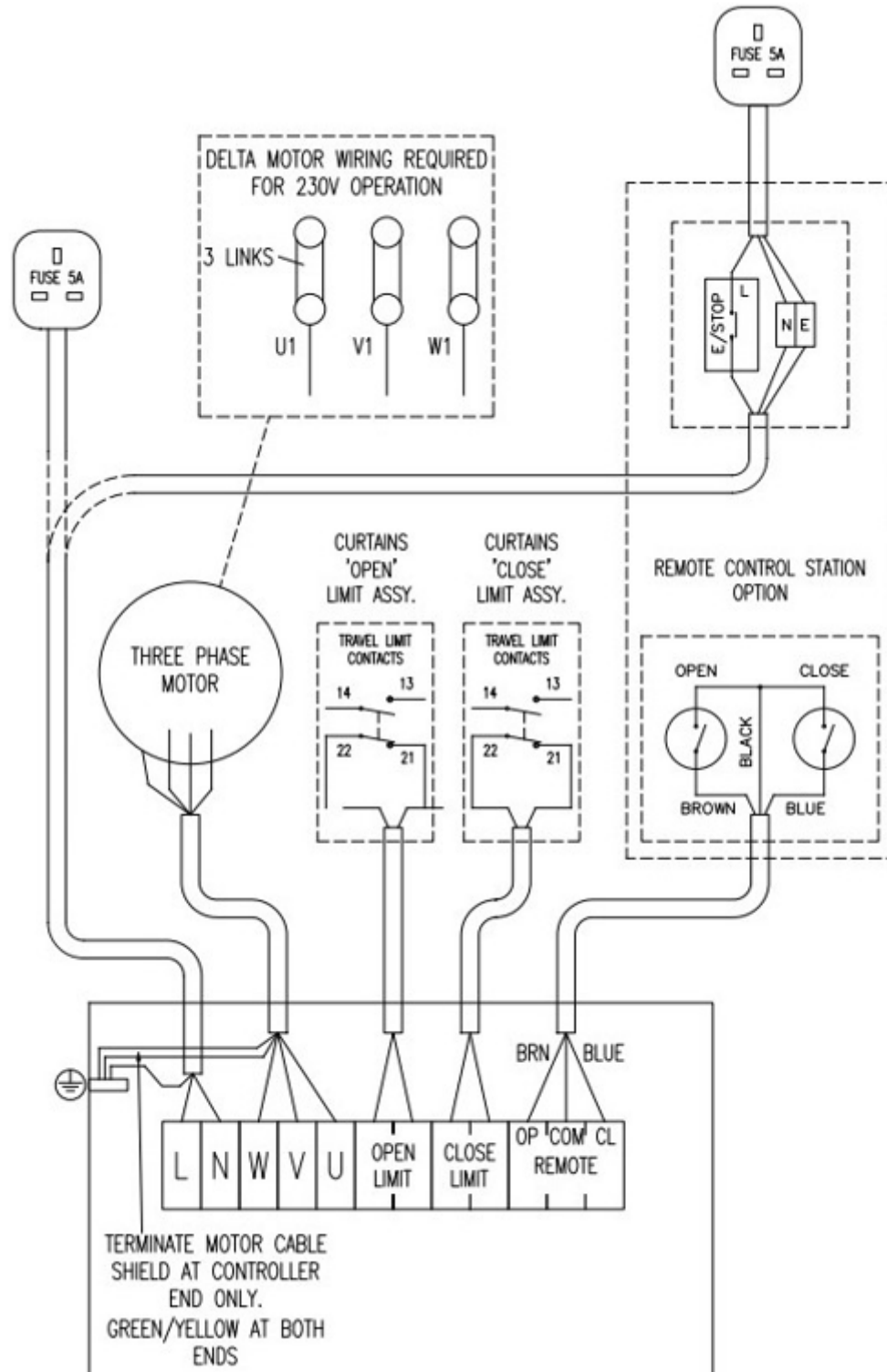

## COMMISSIONING

Upon installation record the following:

- Type of Six Track.
- Place and date installed.
- Name and title of installer and organisation.
- Estimated number of operations each week.

## MAINTENANCE AND INSPECTION

Maintenance must only be carried out by approved personnel. Approved personnel must make regular checks of the product. If any damage is seen, including cracks, deformation or missing parts, the product must be removed from service and returned to an Approved Service Agent for evaluation/repair. A full list of approved service agents can be found at [www.doughty-engineering.co.uk](http://www.doughty-engineering.co.uk).

Approved personnel must carry out a visual inspection and a functional test before every use. Approved personnel must carry out more detailed inspection and testing of the product on a regular basis depending on the usage of the product. Written records should be kept from the date the product is put into operation.

## RECORDS

An inspection table can be found at the back of this manual where the maintenance and inspection history of the Six Track can be recorded.



### Warning

The installer/operator must read and understand the instruction manual before using the equipment. Operators should be adequately instructed and fully understand the safe use of the equipment before use.

Failure to carry out maintenance as necessary, including the replacement of parts to the correct standard could render the equipment unsafe and the manufacturer cannot accept any responsibility in this respect.

Do not use this equipment for a purpose that it is not intended. Retain this manual for future reference.

### DISPOSAL

Products that are no longer needed can be scrapped. Preferably remove all steel parts, store part separately before offering them to a scrapping company. The following alloys are used:

- Mild Steel 8.8

### WARRANTY

- For a period of 12 months we undertake to repair, free of charge any damage attributable to faulty materials or workmanship, provided that the appliance is forwarded, freight paid, to our works or one of the Doughty appointed service agents.
- The guarantee-period begins on the day of the delivery, proven by a purchase receipt like an invoice or delivery note or their copies.
- The guarantee is only applicable for new equipment.
- The guarantee does not cover damage due to transport damage, negligent handling, overload or parts subject to normal wear and tear. Nor damages that originate from a case of misuse because of non-observance the instructions in this manual.
- The fitting of non-original replacement parts or modifications of design by third parties invalidates the guarantee.
- Guarantee repairs do not renew nor extend the guarantee-period.
- In case of a claim under the guarantee or spare part requirements please contact your Doughty service agent.
- The manufacturer is not liable for indirect consequential damage or financial loss.
- The manufacturer is not liable for any changes made to the Six Track or for any damage resulting from such changes.

# Installation & Inspection Report

## INSTALLATION

Part No.....	Serial No.....
Customer.....	Location.....
Installation Company.....	
Installed By.....	

INSPECTED BY	DATE	ESTIMATED OPERATIONS	NOTES	SIGNATURE



## EC-DECLARATION OF CONFORMITY

According to the Machinery Directive 2006/42/EEC Annex II

### Doughty Engineering Ltd

Crow Arch Lane  
Ringwood  
Hampshire  
BH24 1NZ

Herewith declares that:

### Six Track Range

Is in compliance with the following harmonized standards/standards/regulations.

### Machinery Directive 2006/42/EEC annex II

- Machinery Directive 2006/42/EC;
- BS EN ISO 12100:2010 – Safety of Machinery – General Principles for Design – Risk Assessment and Risk Reduction.
- BS 7906-1:2005 - Lifting Equipment for Performance, Broadcast and Similar Applications;
- DGUV 17 – Regulations for Stages and Studios
- DGUV Information 215-313

Signed for and behalf of **Doughty Engineering Ltd**

Name **Dan Phillips**

A handwritten signature in black ink, appearing to be "Dan Phillips", is written over the printed name.

Position **Company Director** being the person responsible appointed by the manufacturer.

Company Registration No. London 972614  
Registered Office: Crow Arch Lane, Ringwood, Hants, BH24 1NZ  
Directors: J.C.G. Chiverton. S.C. Wright. D. Phillips. D.M. Chorley



**Doughty Engineering Ltd**

Crow Arch Lane

Ringwood

Hampshire

BH24 1NZ

Telephone: +44 (0) 1425 478961

Email: [sales@doughty-engineering.co.uk](mailto:sales@doughty-engineering.co.uk)

Website: [www.doughty-engineering.co.uk](http://www.doughty-engineering.co.uk)

**Note:** Whilst every effort has been made to ensure that the information contained within this manual is correct, Doughty Engineering does not accept any liability for errors or omissions. Specifications and technical data are intended for guidance purposes only and may vary.