

# CASTOR LOCK INSTRUCTIONS

## CASTOR LOCK OPEN

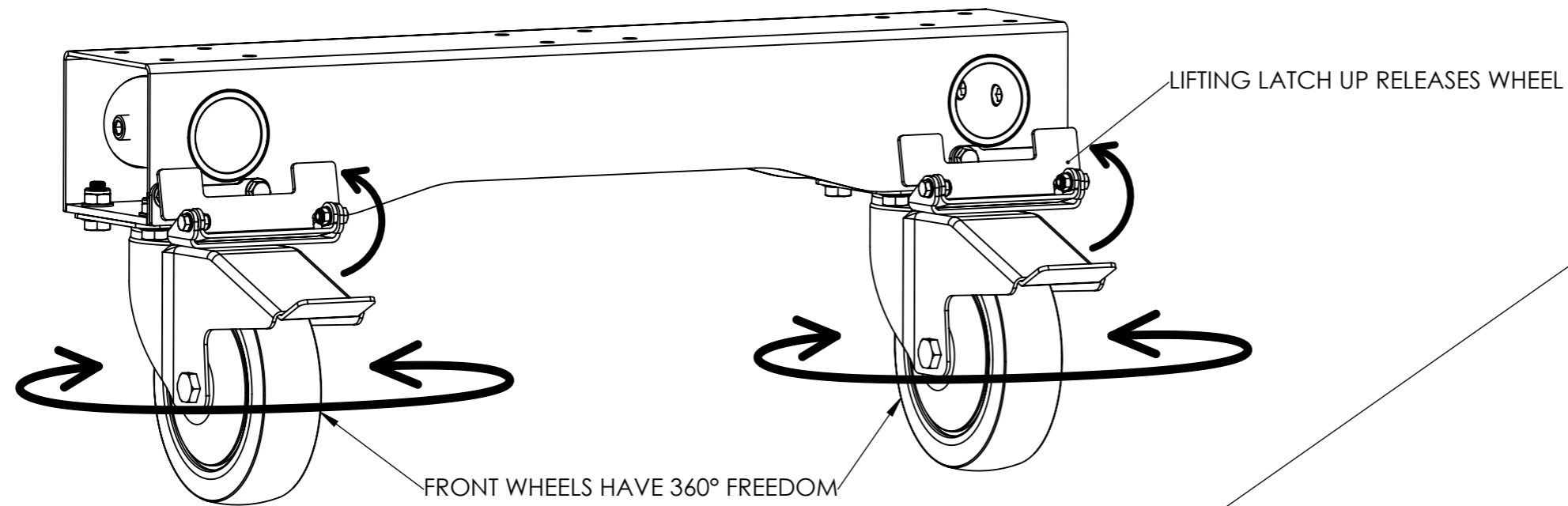

## CASTOR LOCK CLOSED

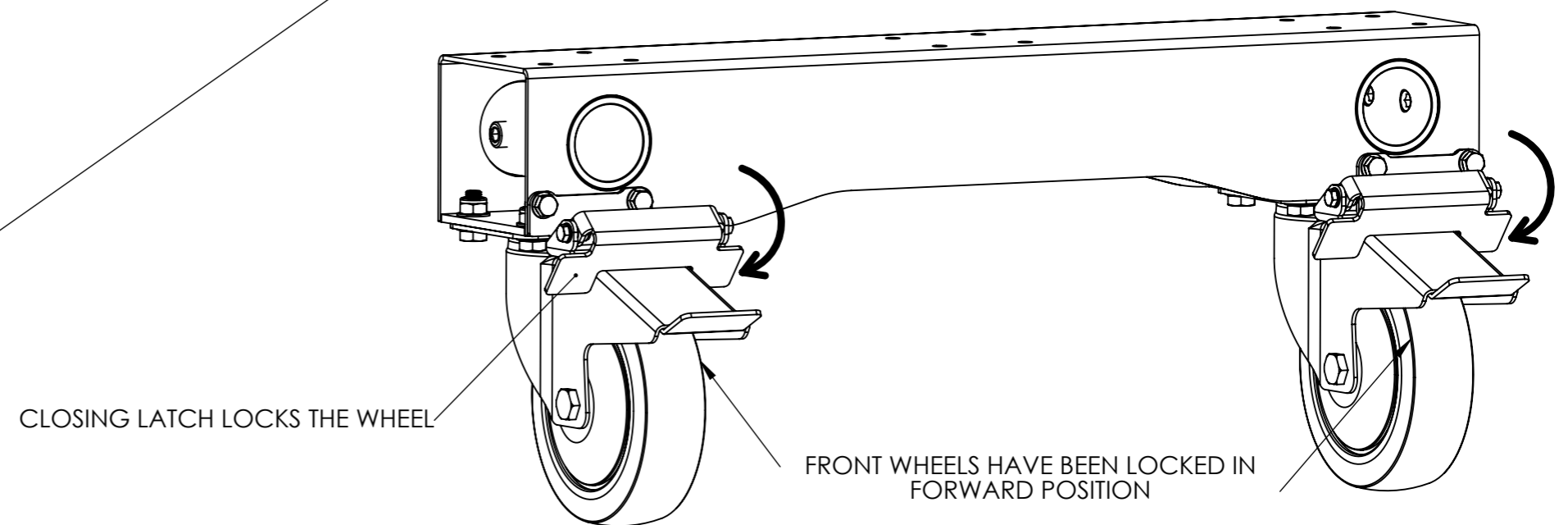

THE CASTOR LOCKS ARE USED TO CONVERT A TROLLEY FROM A 4-WHEEL STEER TO A 2-WHEEL STEER CONFIGURATION. THIS LOCKS THE FRONT WHEELS, ALLOWING ONLY REAR WHEELS TO STEER FOR MORE CONTROL.

USING 4-WHEEL STEER MAYBE PREFERABLE FOR PARKING OR STEERING THE TROLLEY WHEN A SECOND PERSON CAN ASSIST.

THE USE OF THE CASTOR LOCKS IS RECOMMENDED ON SLOPED OR UNEVEN SURFACES, TO CONTROL THE TROLLEY FROM UNEXPECTEDLY VEERING OFF COURSE.

**DOUGHTY**

TITLE CASTOR LOCK INSTRUCTIONS

DWG NO G3508

SHEET 1 OF 1